

Needle Valves

NB, ND, NDH, NF, NFH, NG, NGH, NR, NRG,
NT, NU, NUH and NY Series

Needle Valves
Metering Valves



Contents

Screwed Bonnet Needle Valves

NB Series



B-76

Nonrotating-stem Needle Valves

ND Series and NDH Series



B-81

Forged Body Needle Valves

NF Series and NFH Series



B-85

Integral Bonnet Needle Valves

NG Series and NGH Series



B-91

Rising Plug Valves

NR Series and NRG Series



B-98

Toggle Valves

NT Series



B-102

Union Bonnet Needle Valves

NU Series and NUH Series



B-106

Outside Screw and Yoke (OS&Y) Needle Valves

NY Series



B-112

Notes:

- ⦿ Packing may need to be adjusted during valve use.
- ⦿ For better maintenance, FITOK instrumentation needle valves should be stored in the half-open position.

Screwed Bonnet Needle Valves

NB Series: Working pressure up to 6000 psig



Features

- ⦿ Cold drawn bar as body
- ⦿ Two-piece stem design: Upper stem threads cold rolled and lower stem hardened for high strength and smooth operation
- ⦿ Upper stem thread lubricant isolated from system media
- ⦿ Linear instead of rotary motion of the rising, non-rotating stem minimizes packing abrasion and reduces the friction between the seat and the tip
- ⦿ Safety back seating seal in fully open position
- ⦿ Panel mounting available
- ⦿ Steady and durable fastening of the handle by double lock-pins
- ⦿ Handles of different colors available
- ⦿ Every valve leak tested with Nitrogen or compressed air at the maximum allowable working pressure
- ⦿ Working pressure up to:
 - Stainless steel: 6000 psig (414 bar)
 - Alloy C-276: 6000 psig (414 bar)
 - Alloy 400: 5000 psig (345 bar)
 - Titanium: 3500 psig (241 bar)
 - Brass: 3000 psig (207 bar)
- ⦿ Working temperature:
 - PTFE: -65°F to 450°F (-54°C to 232°C)
 - PEEK: -65°F to 500°F (-54°C to 260°C)
 - Graphite: -65°F to 1200°F (-54°C to 649°C)

Pressure vs. Temperature

NB Series

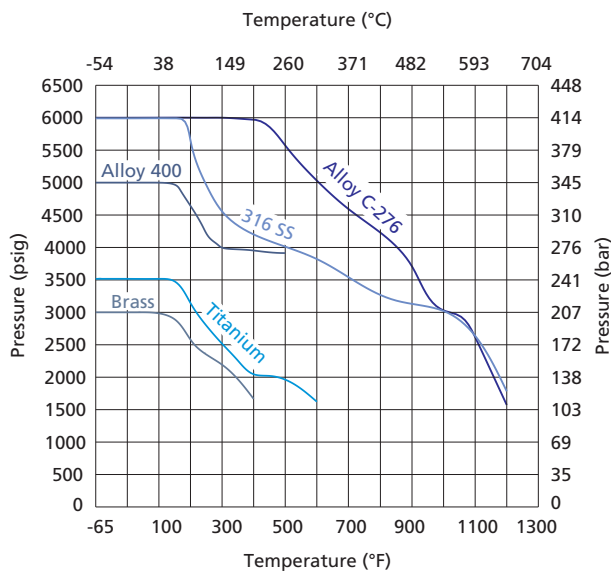

1. Graphs are based on graphite packing.
2. Temperature rating is limited to 200°F (93°C) max. with PCTFE stem tip (soft tip).
3. Contact FITOK Group or our authorized distributors for curve graph of other materials.

Flow Data at 100°F (38°C)

Regulating Stem Tip

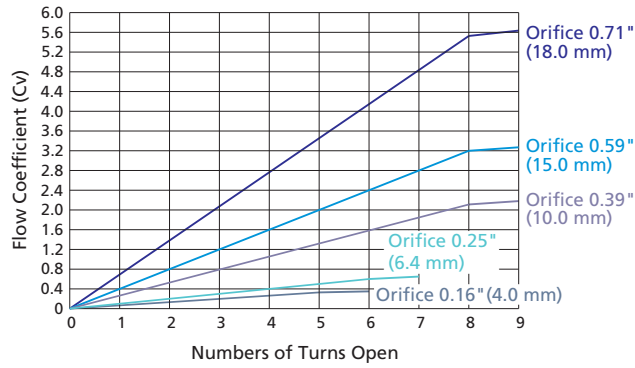

Standard Materials of Construction

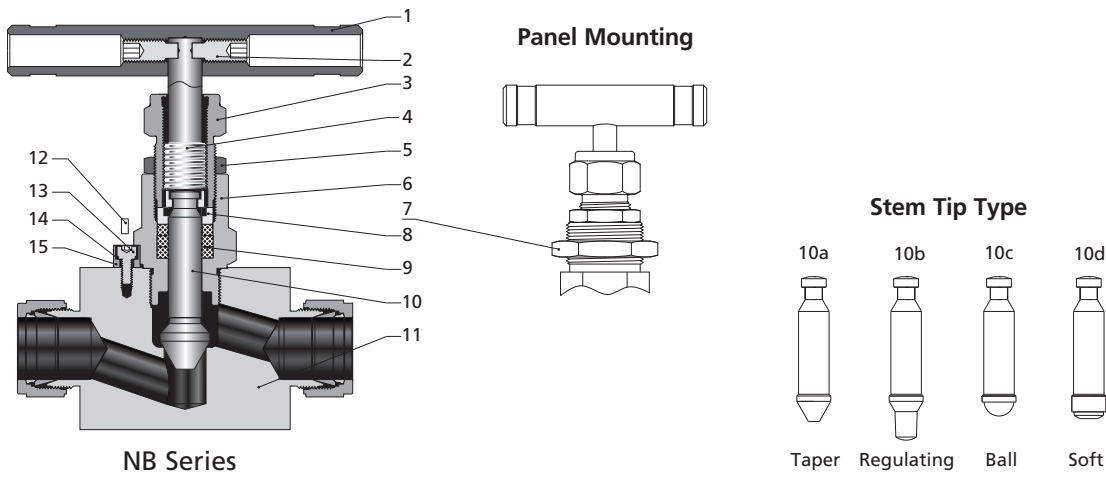

Needle Valves
Metering Valves

Item	Component	Valve Body Material				
		316 SS	Alloy 400	Titanium	Alloy C-276	Brass
		Material Grade/ASTM Specification				
1	Handle	Anodized aluminum or stainless steel or black knob				
2	Set Screw	Galvanized carbon steel				
3	Packing Bolt	304 SS/A479			Brass C36000/B16	
4	Upper Stem	316 SS/A479				
5	Lock Nut	Stainless steel				
6	Bonnet	316 SS/A479	Alloy 400/B164	Titanium Gr 4/B348	Alloy C-276/B574	Brass C36000/B16

B-78 Needle Valves

Item	Component	Valve Body Material				
		316 SS	Alloy 400	Titanium	Alloy C-276	Brass
Material Grade/ASTM Specification						
7	Panel Nut	Stainless steel				Brass C36000/B16
8	Gland	316 SS/A479				
9	Packing	PTFE or PEEK or graphite				
10a 10b 10c	Lower Stem	Hardened 316 SS/A479	Alloy 400/B164	Titanium Gr 4/B348	Alloy C-276/B574	Hardened 316 SS/A479
10d	Stem	316 SS/A479	Alloy 400/B164	Titanium Gr 4/B348	Alloy C-276/B574	316 SS/A479
	Stem Tip	PTFE or PCTFE				
11	Body	316 SS/A479	Alloy 400/B164	Titanium Gr 4/B348	Alloy C-276/B574	Brass C36000/B16
	Seat	Same as body				
12	Lock Pin	Stainless steel				
13	Screw	Stainless steel				
14	Spring Washer	Stainless steel				
15	Bush	Stainless steel				
	Lubricant	Molybdenum disulfide-based				

- Item 12 is applied in valves with orifice of 4.0 and 6.0mm. For valves with orifice of 10.0, 15.0 and 18.0mm, item 13, 14 and 15 are used instead of item 12.
- Contact FITOK Group or our authorized distributors for other materials.

Dimensions

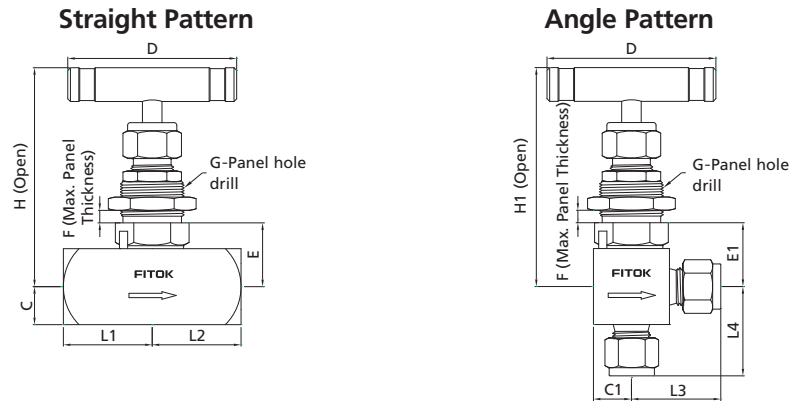

- Ⓞ NB Series Needle Valves are standard without panel mounting. To order needle valves with panel mounting as illustrated, add -Y to the ordering number. Example: NBSS-FNS2-7-Y

Dimensions of NB Series

Basic Ordering Number	Connection Type and Size	Connection Pressure at 100°F (38°C) psig (bar)	Orifice in.(mm)	Cv	Dimensions, in.(mm)													
					L1	L2	L3	L4	C	C1	D	E	E1	F	G	H	H1	
NB□□-FNS2-7	1/8 Female NPT	6000 (414)	0.16 (4.0)	0.35	1.00 (25.4)	1.00 (25.4)	1.00 (25.4)	0.56 (14.3)	0.50 (12.7)	0.50 (12.7)	2.17 (55)	0.84 (21.4)	0.82 (20.9)	0.25 (6.4)	0.77 (19.6)	2.86 (72.7)	2.86 (72.7)	
NB□□-FNS4-7	1/4 Female NPT				1.06 (26.9)	1.06 (26.9)												
NB□□-NS4-7	1/4 Male NPT				1.03 (26.2)	1.03 (26.2)	1.06 (26.9)	1.06 (26.9)										
NB□□-NS6-7	3/8 Male NPT				1.19 (30.2)	1.19 (30.2)												
NB□□-FL4-7	1/4" FITOK																	
NB□□-ML6-7	6 mm FITOK																	
NB□□-ML8-7	8 mm FITOK																	
NB□□-FNS4-8	1/4 Female NPT		0.25 (6.4)	0.85	0.85	1.12 (28.6)	1.12 (28.6)	1.12 (28.6)	0.63 (15.9)	0.56 (14.3)	0.56 (14.3)	2.50 (63.5)	0.89 (22.5)	0.89 (22.5)	0.38 (9.7)	0.96 (24.4)	3.50 (88.9)	3.50 (88.9)
NB□□-FNS6-8	3/8 Female NPT					1.12 (28.6)	1.12 (28.6)											
NB□□-NS6-8	3/8 Male NPT					1.41 (35.8)	1.41 (35.8)	1.32 (33.6)	1.32 (33.6)									
NB□□-FL6-8	3/8" FITOK					1.52 (38.6)	1.52 (38.6)	1.42 (36.1)	1.42 (36.1)									
NB□□-FL8-8	1/2" FITOK																	

FITOK

Dimensions of NB Series

Basic Ordering Number	Connection Type and Size	Connection Pressure at 100°F (38°C) psig (bar)	Orifice in.(mm)	Cv	Dimensions, in.(mm)																
					Inlet/Outlet	316 SS	L1	L2	L3	L4	C	C1	D	E	E1	F	G	H	H1		
NB□□-ML10-8	10 mm FITOK	6000 (414)	0.25 (6.4)	0.85	1.42 (36.1)	1.42 (36.1)	1.33 (33.8)	1.33 (33.8)													
NB□□-ML12-8	12 mm FITOK				1.52 (38.6)	1.52 (38.6)															
NB□□-ML14-8	14 mm FITOK				1.56 (39.7)	1.56 (39.7)	1.42 (36.1)	1.42 (36.1)													
NB□□-TS6-8-G	3/8" TS																				
NB□□-TS8-8-G	1/2" TS																				
NB□□-MTS12-8-G	12 mm MTS				1.13 (28.6)	1.13 (28.6)	1.13 (28.6)	1.13 (28.6)													
NB□□-MTS14-8-G	14 mm MTS										0.56 (14.3)	0.56 (14.3)	2.50 (63.5)	0.89 (22.5)	0.89 (22.5)	0.38 (9.7)	0.96 (24.4)	3.50 (88.9)	3.50 (88.9)		
NB□□-MTS16-8-G	16 mm MTS																				
NB□□-MTB14-8-G	14 mm MTB				1.50 (38.1)	1.50 (38.1)	1.50 (38.1)	1.50 (38.1)													
NB□□-MTB16-8-G	16 mm MTB																				
NB□□-UMB14-8	14 mm UMB																				
NB□□-UMB16-8	16 mm UMB				2.92 (74.1)	2.92 (74.1)															
NB□□-MS20-8	M20 x 1.5 Male Metric				1.50 (38.1)	1.50 (38.1)															
NB□□-MS22-8	M22 x 1.5 Male Metric																				
NB□□-FNS8-9	1/2 Female NPT	5800 (400)	0.39 (10.0)	2.18																	
NB□□-FNS12-9	3/4 Female NPT				1.75 (44.5)	1.75 (44.5)	1.63 (41.3)	1.50 (38.1)													
NB□□-NS12-9	3/4 Male NPT						1.50 (38.1)														
NB□□-FL12-9	3/4" FITOK																				
NB□□-ML14-9	14 mm FITOK				6000 (414)																
NB□□-ML16-9	16 mm FITOK				5800 (400)																
NB□□-ML18-9	18 mm FITOK				5370 (370)																
NB□□-MTS14-9-G	14 mm MTS																				
NB□□-MTS16-9-G	16 mm MTS																				
NB□□-TS12-9-G	3/4" TS																				
NB□□-UMB14-9	14 mm UMB																				
NB□□-MS27-9	M27 x 2 Male Metric	6000 (414)																			
NB□□-FNS12-6	3/4 Female NPT	5000 (345)	0.59 (15.0)	3.27																	
NB□□-TS16-6-G	1" TS						1.75 (44.5)	1.14 (29.0)													
NB□□-MTS25-6-G	25 mm MTS				1.75 (44.5)	1.75 (44.5)	1.75 (44.5)	1.75 (44.5)	1.14 (29.0)	0.88 (22.2)	5.00 (127)	1.70 (43.2)	1.43 (36.4)	0.38 (9.7)	1.28 (32.5)	5.00 (127)	4.72 (120)				
NB□□-MTS28-6-G	28 mm MTS				5770 (398)																
NB□□-PS12-6-G	3/4 PS				4350 (300)																
NB□□-FNS16-0	1 Female NPT				6000 (414)	0.71 (18.0)	5.65														
NB□□-MTS25-0-G	25 mm MTS							1.97 (50.0)	1.97 (50.0)			1.24 (31.5)		5.00 (127)						5.25 (133.3)	
NB□□-TS16-0-G	1" TS																				
NB□□-MTS28-0-G	28 mm MTS																				
NB□□-PS12-0-G	3/4 PS																				
NB□□-PS16-0-G	1 PS	3700 (255)																			

1. Connection type of "FITOK" means FITOK double ferrule tube fittings. When the connection type of valves is FITOK double ferrule tube fitting, the working pressures of the valves are related to the wall thickness of tubing applied. For specific working pressure of the valves, please refer to the allowable working pressures in FITOK Catalog Tubing.
2. Connection type of "TS" means fractional tube socket weld. "MTS" means metric tube socket weld. "MTB" means metric tube butt weld. "UMB" means rotatable metric tube butt weld. "PS" means pipe socket weld.
3. Sizes and types listed are standard. Other sizes and types are available upon request. For details, please contact FITOK Group or our authorized distributors.
4. Dimensions are shown with FITOK tube fitting nuts finger-tight. All dimensions are for reference only and are subject to change. For dimensions not shown above, please contact FITOK Group or our authorized distributors.

Ordering Number Description

NBSS - FL8 - ML12 - 8WB - GYM - ASF2

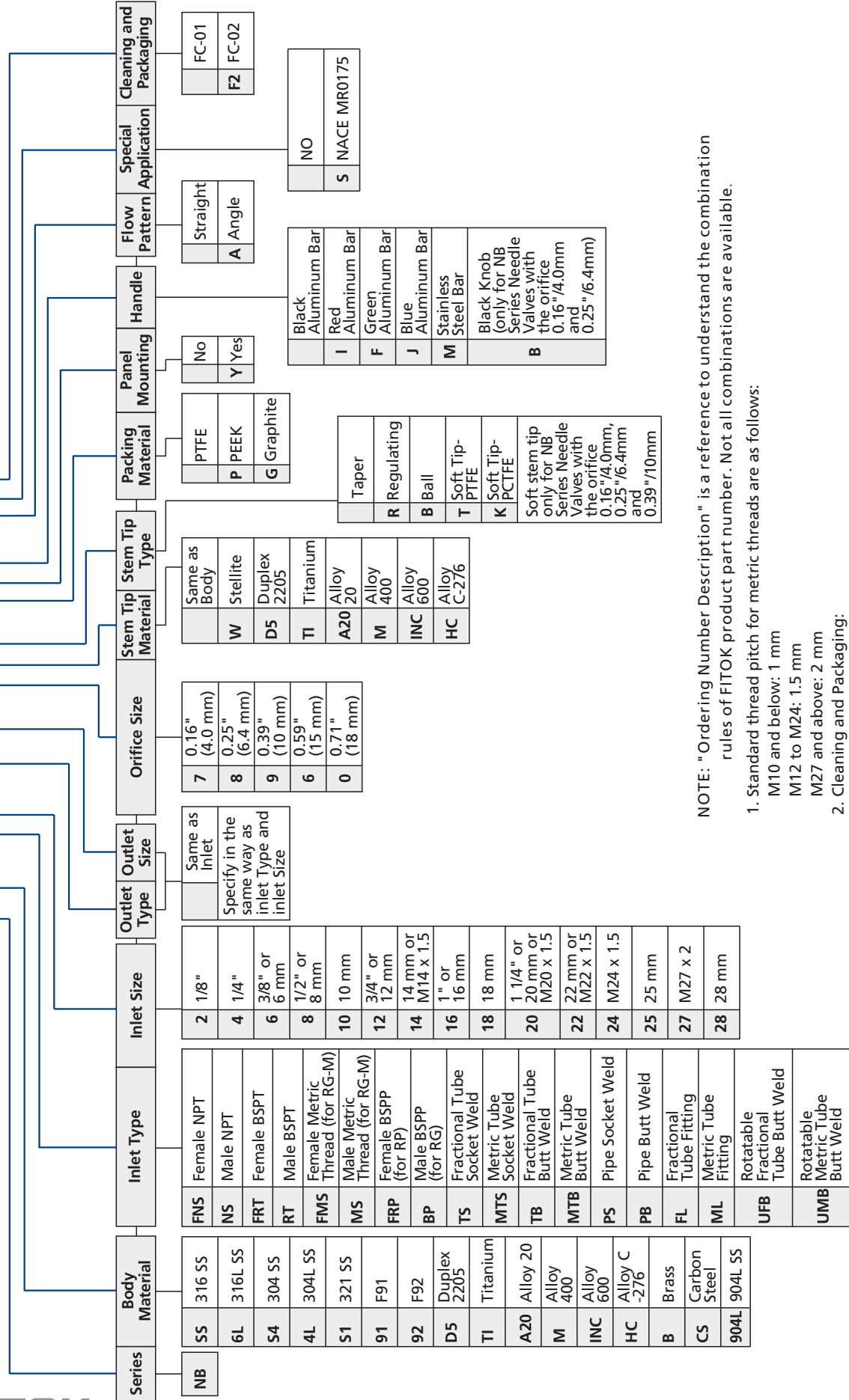

NOTE: "Ordering Number Description" is a reference to understand the combination rules of FITOK product part number. Not all combinations are available.

1. Standard thread pitch for metric threads are as follows:

- M10 and below: 1 mm
- M12 to M24: 1.5 mm
- M27 and above: 2 mm

2. Cleaning and Packaging:

- FC-01: Standard cleaning and packaging for general industrial procedures.
- FC-02: Special cleaning and packaging for wetted system components to ensure compliance with product cleanliness requirement of ASTM G93 Level C.

Nonrotating-stem Needle Valves

ND Series: Working pressure up to 3000 psig

NDH Series: Working pressure up to 5000 psig

Features

- ⦿ One-piece forged body
- ⦿ Straight and angle pattern
- ⦿ Compact design
- ⦿ Non-rotating stem
- ⦿ Specially designed handle to stop contamination from entering into the valve
- ⦿ Every valve leak tested with Nitrogen or compressed air at the maximum allowable working pressure
- ⦿ Working pressure up to:
 - ND Series—Stainless steel: 3000 psig (207 bar)
 - Brass: 3000 psig (207 bar)
 - NDH Series—Stainless steel: 5000 psig(345 bar)
- ⦿ Working temperature with stem tip:
 - PCTFE stem tip: -20°F to 200°F (-28°C to 93°C)
 - PEEK stem tip: -20°F to 400°F (-28°C to 204°C)
- ⦿ Working temperature with O-ring:
 - Fluorocarbon Rubber (FKM) : -20°F to 400°F (-28°C to 204°C)
 - Nitrile Butadiene Rubber (NBR) : -20°F to 212°F (-28°C to 100°C)
 - Ethylene Propylene Diene Rubber (EPDM): -20°F to 300°F (-28°C to 148°C)



Needle Valves
Metering Valves

Pressure vs. Temperature

ND Series

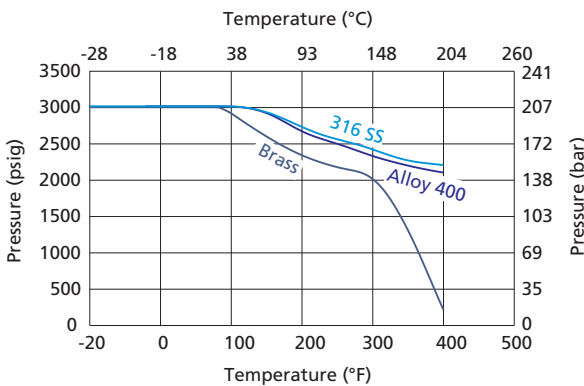

NDH Series

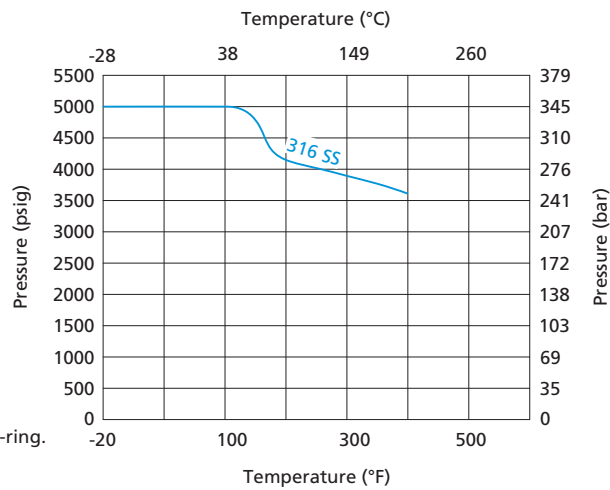

1. The graphs are based on PEEK stem tip and Fluorocarbon rubber (FKM) O-ring.
2. Contact FITOK Group or our authorized distributors for curve graph of other materials.

Flow Data at 100°F (38°C)

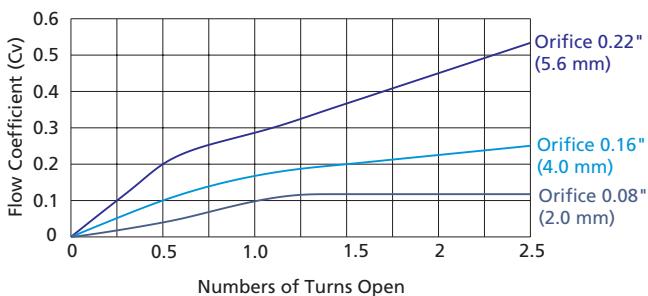

Standard Materials of Construction

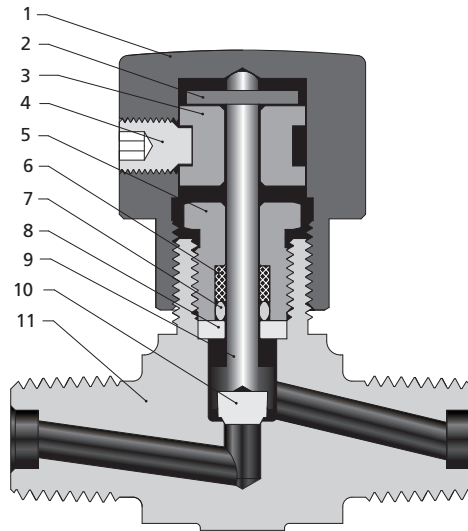

Item	Component	Valve Body Material				
		316 SS	304 SS	321 SS	Brass	Alloy 400
Material Grade/ASTM Specification						
1	Handle	Anodized aluminum				
2	Stop Pin	Stainless steel				
3	Spool	Aluminum				
4	Set Screw	Stainless steel				
5	Packing Bolt	304 SS/A479			Brass C36000/B16	Alloy 400/B164
6	Backup Ring	PTFE/D1710				
7	O-ring	Fluorocarbon Rubber (FKM), Nitrile Butadiene Rubber (NBR) or Ethylene Propylene Diene Rubber (EPDM)				
8	Washer	316 SS/A479				Alloy 400/B164
9	Stem	316 SS/A479				Alloy 400/B164
10	Stem Tip	PCTFE or PEEK				
11	Body	316 SS/A182	304 SS/A182	321 SS/A182	Brass C37700/B283	Alloy 400/B564
	Lubricant	Molybdenum disulfide-based				

Note: Contact FITOK Group or our authorized distributors for other materials.

Dimensions

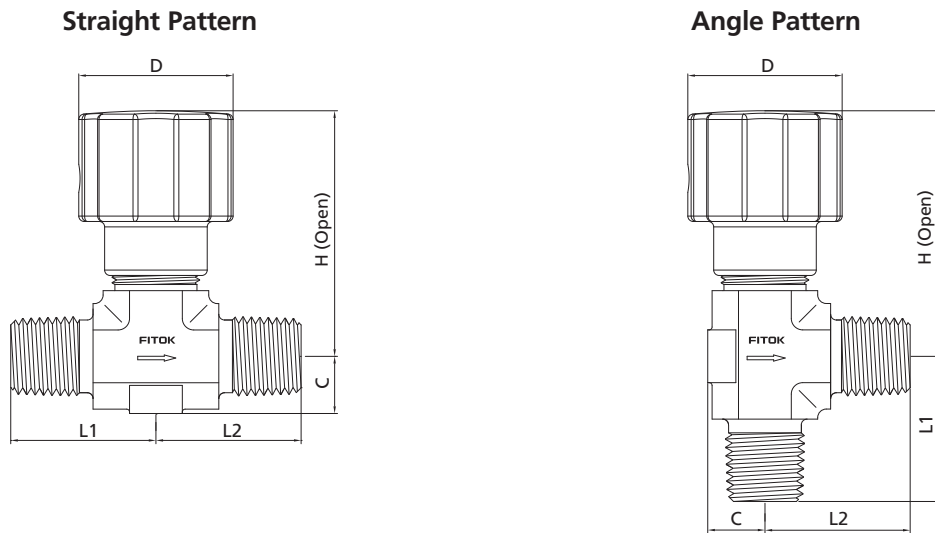

ND and NDH Series

Basic Ordering Number	Connection Type and Size		Orifice in.(mm)	Cv	Dimensions, in.(mm)				
	Inlet	Outlet			L1	L2	C	D	H
ND□□-NS2-5	1/8 Male NPT	1/8 Male NPT	0.08 (2.0)	0.12	0.81 (20.6)	0.81 (20.6)	0.32 (8.1)	1.06 (26.9)	1.86 (47.2)
ND□□-NS2-FL2-5	1/8 Male NPT	1/8" FITOK							
ND□□-FL2-5	1/8" FITOK	1/8" FITOK							
ND□□-ML3-5	3 mm FITOK	3 mm FITOK							
ND□□-NS4-7	1/4 Male NPT	1/4 Male NPT	0.16 (4.0)	0.27	0.98 (25.0)	0.98 (25.0)	0.39 (10.0)	1.13 (28.7)	1.86 (47.2)
ND□□-NS4-FL4-7	1/4 Male NPT	1/4 FITOK							
ND□□-FL4-7	1/4" FITOK	1/4" FITOK							
ND□□-ML6-7	6 mm FITOK	6 mm FITOK							
ND□□-ML8-7	8 mm FITOK	8 mm FITOK	0.22 (5.6)	0.53	1.18 (30.0)	1.18 (30.0)	0.49 (12.5)	1.22 (31.0)	2.02 (51.3)
ND□□-FNS4-8	1/4 Female NPT	1/4 Female NPT			1.06 (26.9)	1.06 (26.9)			
ND□□-NS6-8	3/8 Male NPT	3/8 Male NPT			1.12 (28.6)	1.12 (28.6)			
ND□□-FL6-8	3/8" FITOK	3/8" FITOK			1.29 (32.8)	1.29 (32.8)			
ND□□-FL8-8	1/2" FITOK	1/2" FITOK			1.40 (35.6)	1.40 (35.6)			
ND□□-ML10-8	10 mm FITOK	10 mm FITOK			1.30 (33.0)	1.30 (33.0)			
ND□□-ML12-8	12 mm FITOK	12 mm FITOK	1.40 (35.6)	1.40 (35.6)					
NDH□□-NS2-5	1/8 Male NPT	1/8 Male NPT	0.08 (2.0)	0.12	0.81 (20.6)	0.81 (20.6)	0.32 (8.1)	1.06 (26.9)	1.86 (47.2)
NDH□□-FL2-5	1/8" FITOK	1/8" FITOK							
NDH□□-ML3-5	3 mm FITOK	3 mm FITOK							
NDH□□-NS4-7	1/4 Male NPT	1/4 Male NPT	0.16 (4.0)	0.27	0.98 (25.0)	0.95 (25.0)	0.39 (10.0)	1.13 (28.7)	1.98 (50.2)
NDH□□-FL4-7	1/4" FITOK	1/4" FITOK							
NDH□□-ML6-7	6 mm FITOK	6 mm FITOK							

1. Connection type of "FITOK" means FITOK double ferrule tube fittings. When the connection type of valves is FITOK double ferrule tube fitting, the working pressures of the valves are related to the wall thickness of used applied. For specific working pressure of the valves, please refer to the allowable working pressures in FITOK Catalog Tubing.
2. Sizes and types listed are standard. Other sizes and types are available upon request. For details, please contact FITOK Group or our authorized distributors.
3. Dimensions are shown with FITOK tube fitting nuts finger-tight. All dimensions are for reference only and are subject to change. For dimensions not shown above, please contact FITOK Group or our authorized distributors.

Ordering Number Description

NDSS – FNS4 – ML8 – 7PE – ASF2

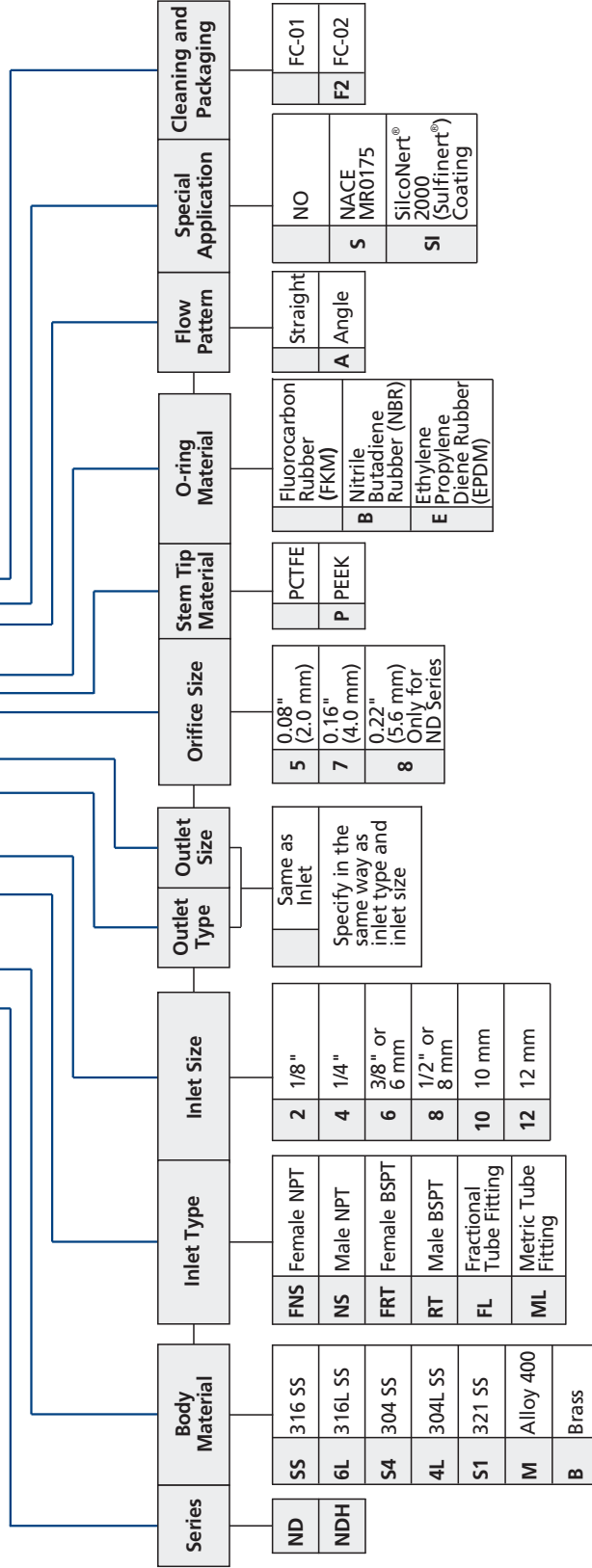

NOTE: "Ordering Number Description" is a reference to understand the combination rules of FITOK product part number. Not all combinations are available.

- Cleaning and Packaging:
 - FC-01: Standard cleaning and packaging for general industrial procedures.
 - FC-02: Special cleaning and packaging for wetted system components to ensure compliance with product cleanliness requirement of ASTM G93 Level C.
- Special Application:
 - Plural special application designators available in one ordering number, example: NDSS-NS4-7-SSI. SilcoNert® 2000 (Sulfinert®) coating: Wetted metal components SilcoNert® 2000 (Sulfinert®) coated.

Forged Body Needle Valves

NF Series: Working pressure up to 6000 psig

NFH Series: Working pressure up to 10000 psig

Features

- ⦿ One-piece forged body
- ⦿ Two-piece stem design: Upper stem threads cold rolled and lower stem hardened for high strength and smooth operation
- ⦿ Upper stem thread lubricant isolated from system media
- ⦿ Linear instead of rotary motion of the rising, non-rotating stem minimizes packing abrasion and reduces the friction between the seat and the tip
- ⦿ Panel mounting available
- ⦿ Steady and durable fastening of the handle by double lock-pins
- ⦿ Handles of different colors available
- ⦿ Every valve leak tested with Nitrogen or compressed air (NF Series) at the maximum allowable working pressure or with water (NFH Series) at 1.1 times the maximum allowable working pressure
- ⦿ Working pressure up to:
 - NF Series—Stainless steel: 6000 psig (414 bar)
 - Alloy C-276: 6000 psig (414 bar)
 - Alloy 400: 5000 psig (345 bar)
 - Titanium: 3500 psig (241 bar)
 - Brass: 3000 psig (207 bar)
- ⦿ NFH Series—Stainless steel: 10000 psig (690 bar)
- ⦿ Working temperature:
 - PTFE: -65°F to 450°F (-54°C to 232°C)
 - PEEK: -65°F to 500°F (-54°C to 260°C)
 - Graphite: -65°F to 1200°F (-54°C to 649°C)



Pressure vs. Temperature

NF Series

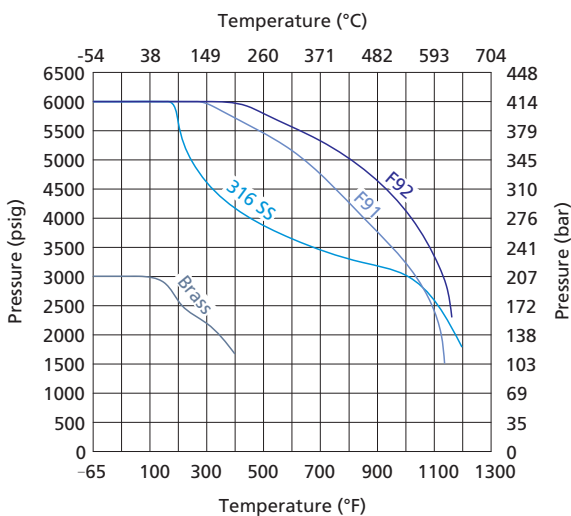

NFH Series

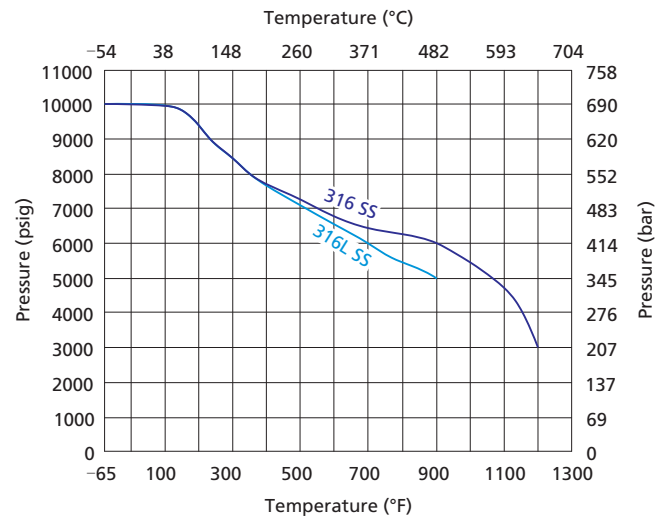

1. Graphs are based on graphite packing.
2. Soft tips are for NF Series only. Temperature rating is limited to 200°F (93°C) max. with PCTFE stem tip (soft tip).
3. Contact FITOK Group or our authorized distributors for curve graph of other materials.

Flow Data at 100°F (38°C)

Regulating Stem Tip

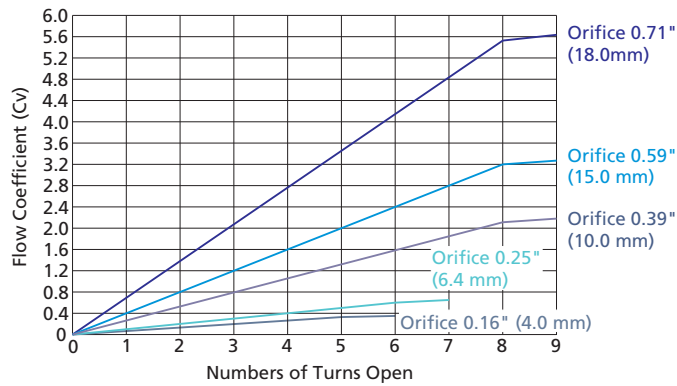

Standard Materials of Construction

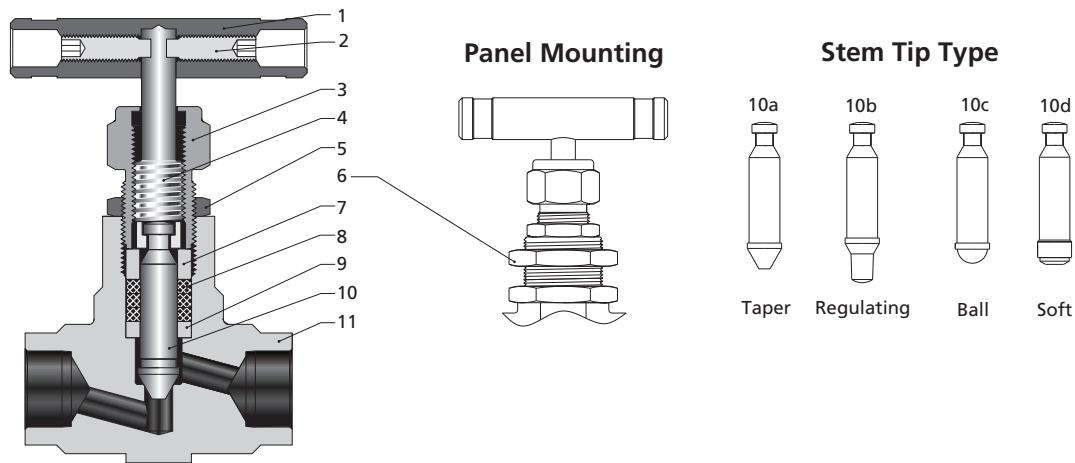

Item	Component	Valve Body Material		
		316 SS	F91	Brass
		Material Grade/ASTM Specification		
1	Handle	Anodized aluminum or stainless steel or black knob		
2	Set Screw	Galvanized carbon steel		
3	Packing Bolt	304 SS/A479	F91/A182	Brass C36000/B16
4	Upper Stem	316 SS/A479		
5	Lock Nut	Stainless steel	1020/A108	Brass C36000/B16
6	Panel Nut	Stainless steel	1020/A108	Brass C36000/B16
7	Gland	316 SS/A479		Brass C36000/B16
8	Packing	PTFE or PEEK or graphite		
9	Packing Washer	316 SS/A479		Brass C36000/B16
10a 10b 10c	Lower Stem	Hardened 316 SS/A479		
10d		Stem	316 SS/A479	
	Stem Tip	PTFE or PCTFE		
11	Body	316 SS/A182	F91/A182	Brass C37700/B283
	Seat	Same as body		
	Lubricant	Molybdenum disulfide-based		

Note: Contact FITOK Group or our authorized distributors for other materials.

Dimensions

Straight Pattern

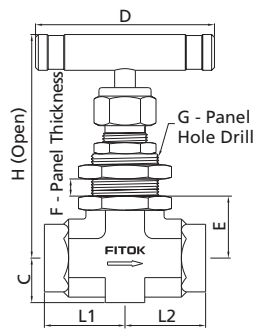

Angle Pattern

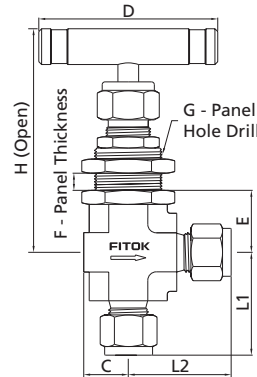

© NF Series Needle Valves are standard without panel mounting. To order needle valves with panel mounting as illustrated, add -Y to the ordering number. Example: NFSS-FNS2-7-Y

Dimensions of NF Series

Basic Ordering Number	Connection Type and Size	Connection Pressure at 100°F (38°C) psig (bar)	Orifice in.(mm)	Cv	Dimensions, in.(mm)												
					L1	L2	H	D	C	E	F	G					
		316 SS															
NF□□-FNS2-7	1/8 Female NPT	6000 (414)	0.16 (4.0)	0.35	1.00 (25.4)	1.00 (25.4)	2.85 (72.5)	2.17 (55)	0.49 (12.5)	0.71 (18.0)	0.25 (6.4)	0.77 (19.6)					
NF□□-FNS4-7	1/4 Female NPT				1.03 (26.2)	1.03 (26.2)											
NF□□-FL4-7	1/4" FITOK				1.22 (30.9)	1.22 (30.9)											
NF□□-ML6-7	6 mm FITOK				1.25 (31.75)	1.25 (31.75)											
NF□□-ML8-7	8 mm FITOK				1.03 (26.2)	1.03 (26.2)											
NF□□-NS4-7	1/4 Male NPT																
NF□□-NS6-7	3/8 Male NPT																
NF□□-FO4-7	1/4" Male FO				1.13 (28.6)	1.13 (28.6)											
NF□□-FR4-7	1/4" Male FR																
NF□□-FNS4-8	1/4 Female NPT																
NF□□-FNS6-8	3/8 Female NPT																
NF□□-NS6-8	3/8 Male NPT																
NF□□-FL6-8	3/8" FITOK																
NF□□-ML10-8	10 mm FITOK																
NF□□-ML12-8	12 mm FITOK																
NF□□-ML14-8	14 mm FITOK																
NF□□-FNS8-8	1/2 Female NPT																
NF□□-NS8-8	1/2 Male NPT																
NF□□-FL8-8	1/2" FITOK																
NF□□-TS6-8-G	3/8" TS																
NF□□-TS8-8-G	1/2" TS																
NF□□-MTS12-8-G	12 mm MTS																
NF□□-MTS14-8-G	14 mm MTS																
NF□□-MTS16-8-G	16 mm MTS																
NF□□-MTB14-8-G	14 mm MTB																
NF□□-MTB16-8-G	16 mm MTB																
NF□□-UMB14-8	14 mm UMB																
NF□□-UMB16-8	16 mm UMB																
NF□□-FO8-8	1/2" Male FO																
NF□□-FR8-8	1/2" Male FR																
NF□□-MS20-8	M20 x 1.5 Male Metric																

Needle Valves
Metering Valves

Dimensions of NF Series

Basic Ordering Number	Connection Type and Size	Connection Pressure at 100°F (38°C) psig (bar)	Orifice in.(mm)	Cv	Dimensions, in.(mm)								
					Inlet/Outlet	316 SS	L1	L2	H	D	C	E	F
NF□□-MS22-8	M22 x 1.5 Male Metric	6000 (414)	0.25 (6.4)	0.85	1.50 (38.1)	1.50 (38.1)	3.38 (85.8)	2.50 (63.5)	0.62 (15.8)	0.87 (22.0)	0.38 (9.7)	0.96 (24.4)	
NF□□-FNS8-9	1/2 Female NPT				1.56 (39.7)	1.56 (39.7)			0.80 (20.4)				
NF□□-NS12-9	3/4 Male NPT												
NF□□-FL12-9	3/4" FITOK				5800 (400)								
NF□□-ML14-9	14 mm FITOK				6000 (414)								
NF□□-ML16-9	16 mm FITOK				5800 (400)								
NF□□-ML18-9	18 mm FITOK				5370 (370)						0.76 (19.4)		
NF□□-ML20-9	20 mm FITOK	5510 (380)											
NF□□-MTS14-9-G	14 mm MTS	6000 (414)	0.39 (10.0)	2.18			3.86 (98.0)	3.50 (88.9)		1.10 (28.3)	0.38 (9.7)	1.08 (27.5)	
NF□□-MTS16-9-G	16 mm MTS												
NF□□-MTS18-9-G	18 mm MTS												
NF□□-TS12-9-G	3/4" TS				1.56 (39.7)	1.56 (39.7)							
NF□□-PS8-9-G	1/2 PS										0.80 (20.4)		
NF□□-MTB16-9-G	16 mm MTB												
NF□□-UMB14-9	14 mm UMB										0.76 (19.4)		
NF□□-UMB16-9	16 mm UMB												
NF□□-MS27-9	M27 x 2 Male Metric												
NF□□-FNS12-6	3/4 Female NPT												
NF□□-TS16-6-G	1" TS	5500 (379)	0.59 (15.0)	3.27									
NF□□-MTS25-6-G	25 mm MTS				1.97 (50.0)	1.97 (50.0)							
NF□□-MTS28-6-G	28 mm MTS						5.00 (127)	5.00 (127)	1.08 (27.5)	1.61 (41.0)	0.38 (9.7)	1.45 (36.8)	
NF□□-PS12-6-G	3/4 PS				6000 (414)								
NF□□-PB12-6-G	3/4 PB												
NF□□-FL12-6	3/4" FITOK	5800 (400)			2.35 (59.7)	2.35 (59.7)							
NF□□-ML20-6	20 mm FITOK	5510 (380)											
NF□□-TS16-0-G	1" TS	6000 (414)	0.71 (18.0)	5.65									
NF□□-MTS25-0-G	25 mm MTS				1.97 (50.0)	1.97 (50.0)	5.33 (135.4)	5.00 (127)	1.08 (27.5)	1.61 (41.0)	0.38 (9.7)	1.45 (36.8)	
NF□□-MTS28-0-G	28 mm MTS				5500 (379)								
NF□□-PS12-0-G	3/4 PS				6000 (414)								
NF□□-PB16-0-G	1 PB				5720 (394)								

1. Connection type of "FITOK" means FITOK double ferrule tube fittings. When the connection type of valves is FITOK double ferrule tube fitting, the working pressures of the valves are related to the wall thickness of tubing applied. For specific working pressure of the valves, please refer to the allowable working pressures in FITOK Catalog Tubing.
2. Connection type of "FO" means O-ring face seal fittings. "FR" means metal gasket face seal fittings. "TS" means fractional tube socket weld. "MTS" means metric tube socket weld. "MTB" means metric tube butt weld. "UMB" means rotatable metric tube butt weld. "PS" means pipe socket weld. "PB" means pipe butt weld.
3. Sizes and types listed are standard. Other sizes and types are available upon request. For details, please contact FITOK Group or our authorized distributors.
4. Dimensions are shown with FITOK tube fitting nuts finger-tight. All dimensions are for reference only and are subject to change. For dimensions not shown above, please contact FITOK Group or our authorized distributors.

Straight Pattern

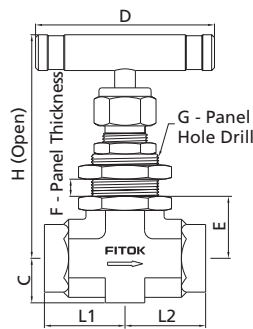

Angle Pattern

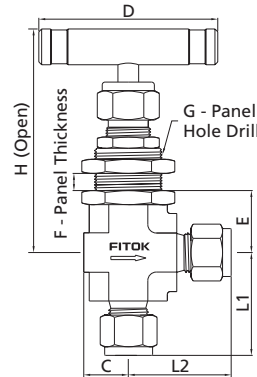

© NFH Series Needle Valves are standard without panel mounting. To order needle valves with panel mounting as illustrated, add -Y to the ordering number. Example: NFHSS-FNS2-7-Y

Dimensions of NFH Series

Basic Ordering Number	Connection Type and Size	Connection Pressure at 100°F (38°C) psig (bar)	Orifice in.(mm)	Cv	Dimensions, in.(mm)							
					Inlet/Outlet	316 SS	L1	L2	H	D	C	E
NFH□□-FL4-7	1/4" FITOK	10000 (690)	0.16 (4.0)	0.35	1.41 (35.8)	1.41 (35.8)	2.85 (72.5)	2.17 (55)	0.62 (15.8)	0.76 (19.4)	0.25 (6.4)	0.77 (19.6)
NFH□□-FNS2-7	1/8 Female NPT				1.00 (25.4)	1.00 (25.4)						
NFH□□-FNS4-7	1/4 Female NPT				1.06 (26.2)	1.06 (26.2)						
NFH□□-NS4-7	1/4 Male NPT				1.22 (30.9)	1.22 (30.9)						
NFH□□-FNS4-NS4-7	1/4 Female NPT				1.06 (26.2)	1.22 (30.9)						
NFH□□-TS4-7-G	1/4" TS				1.06 (26.2)	1.06 (26.2)						
NFH□□-FNS4-8	1/4 Female NPT				9000 (620)	0.25 (6.4)						
NFH□□-FNS6-8	3/8 Female NPT	1.50 (38.1)	1.50 (38.1)									
NFH□□-NS6-8	3/8 Male NPT											
NFH□□-TS8-9-G	1/2" TS	10000 (690)	0.39 (10.0)	2.18	1.56 (39.7)	1.56 (39.7)	3.86 (98.0)	3.50 (88.9)	0.76 (19.4)	1.10 (28.3)	0.38 (9.7)	1.08 (27.5)
NFH□□-MTS16-9-G	16 mm MTS								0.80 (20.4)			
NFH□□-MTB25-9-G	25 mm MTB											
NFH□□-FNS8-9	1/2 Female NPT						4.16 (105.7)	0.88 (22.2)				

1. Connection type of "FITOK" means FITOK double ferrule tube fittings. When the connection type of valves is FITOK double ferrule tube fitting, the working pressures of the valves are related to the wall thickness of tubing applied. For specific working pressure of the valves, please refer to the allowable working pressures in FITOK Tubing catalog.
2. Connection type of "TS" means fractional tube socket weld. "MTS" means metric tube socket weld. "MTB" means metric tube butt weld.
3. Sizes and types listed are standard. Other sizes and types are available upon request. For details, please contact FITOK Group or our authorized distributors.
4. Dimensions are shown with FITOK tube fitting nuts finger-tight. All dimensions are for reference only and are subject to change. For dimensions not shown above, please contact FITOK Group or our authorized distributors.

Needle Valves
Metering Valves

Ordering Number Description

NFS4 - TS16 - MTS25 - 6WR - GYM - ASF2

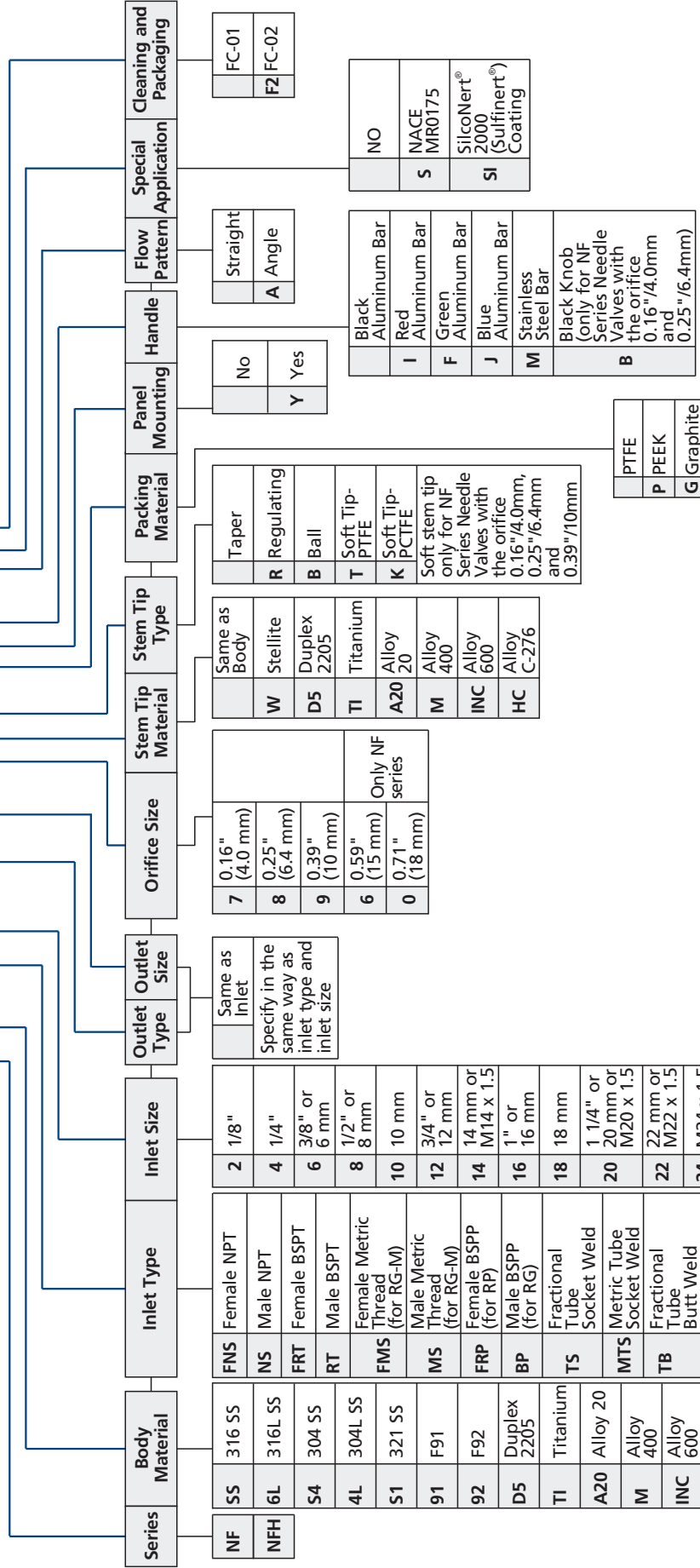

NOTE: "Ordering Number Description" is a reference to understand the combination rules of FITOK product part number. Not all combinations are available.

- Standard thread pitch for metric threads are as follows:
M10 and below: 1 mm
M12 to M24: 1.5 mm
M27 and above: 2 mm
- FO means FITOK O-ring face seal fittings.
- FR means FITOK metal gasket face seal fittings.
- Cleaning and Packaging:
FC-01: Standard cleaning and packaging for general industrial procedures.
FC-02: Special cleaning and packaging for wetted system components to ensure compliance with product cleanliness requirement of ASTM G93 Level C.
- Special Application:
Plural special application designators available in one ordering number, example: NFSS-NS4-7-SSI.
SilcoNert® 2000 (Sulfinert®) coating: Wetted metal components SilcoNert® 2000 (Sulfinert®) coated.

Integral Bonnet Needle Valves

NG Series: Working pressure up to 3000 psig

NGH Series: Working pressure up to 5000 psig

Features

- ⦿ One-piece forged body
- ⦿ Easy external adjustments by packing nut
- ⦿ Live-loaded packing system
- ⦿ Handles of different colors available
- ⦿ Compact design
- ⦿ Panel mounting available
- ⦿ Every valve leak tested with Nitrogen or compressed air at the maximum allowable working pressure
- ⦿ Working pressure up to:
 - NG Series—Stainless steel, Brass, Alloy 400: 3000 psig (207 bar)
 - NGH Series—Stainless steel: 5000 psig (345 bar)
- ⦿ Working temperature:
 - PTFE: -65°F to 450°F (-54°C to 232°C)
 - PEEK: -65°F to 500°F (-54°C to 260°C)



Needle Valves
Metering Valves

Pressure vs. Temperature

NG Series

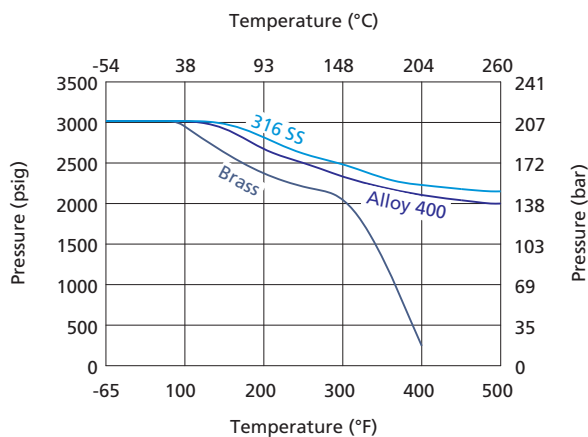

NGH Series

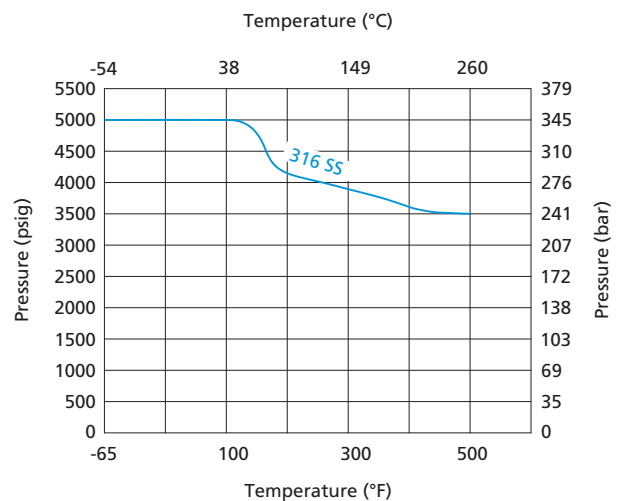

1. Graphs are based on PEEK packing.
2. Temperature rating is limited to 200°F (93°C) max with PCTFE stem tip (soft tip).
3. Contact FITOK Group or our authorized distributors for curve graph of other materials.

Flow Data at 100°F (38°C)

Regulating Stem Tip

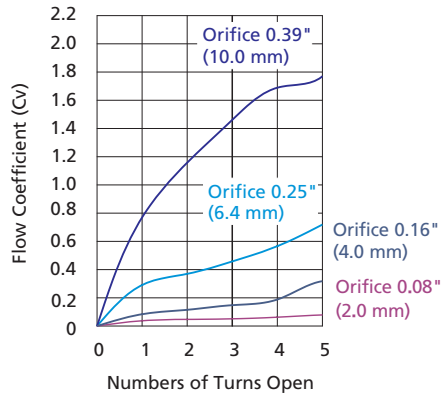

Standard Materials of Construction

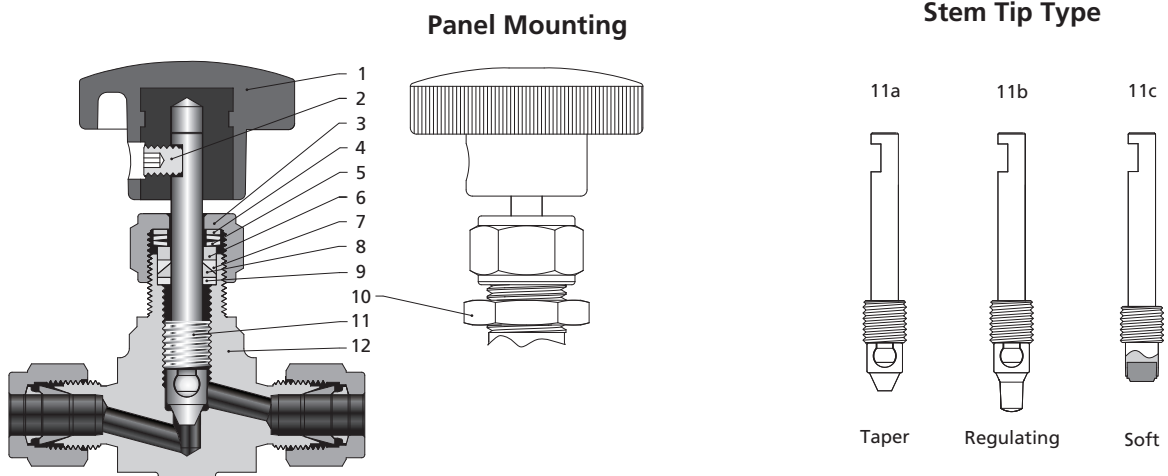

Item	Component	Valve Body Material		
		316 SS	Brass	Alloy 400
		Material Grade/ASTM Specification		
1	Handle	Black knob (aluminum or nylon with copper insert), aluminum alloy or stainless steel bar handle		
2	Set Screw	Galvanized carbon steel		
3	Packing Bolt	304 SS/A479	Brass C36000/B16	304 SS/A479
4	Washer	316 SS/A479		
5	Packing Spring	S17700/A693		
6	Washer	316 SS/A479		
7	Upper Packing	PTFE/PEEK		
8	Lower Packing			
9	Packing Washer	316 SS/A479	Alloy 400/B164	
10	Panel Nut	Stainless steel	Brass C36000/B16	Stainless steel
11a	Stem	316 SS/A479		Alloy 400/B164
11b	Stem Tip	Hardened 316 SS/A479		Alloy 400/B164
11c	Stem	316 SS/A479		Alloy 400/B164
	Stem Tip	PCTFE or PEEK		
12	Body	316 SS/A182	Brass C37700/B283	Alloy 400/B564
	Lubricant	Molybdenum disulfide-based		

Note: Contact FITOK Group or our authorized distributors for other materials.

Dimensions

Straight Pattern

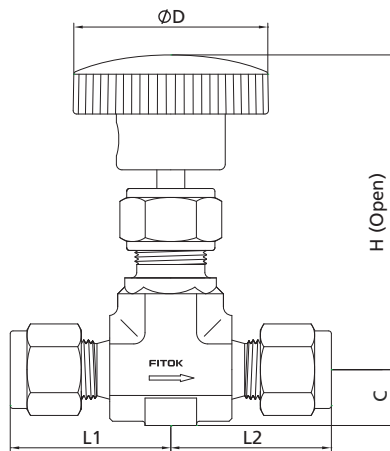

Angle Pattern

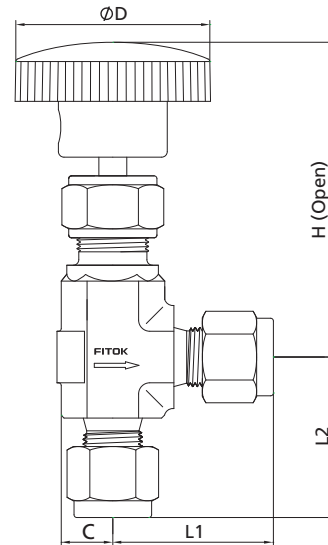

Dimensions of NG Series

Basic Ordering Number	Connection Type and Size		Orifice in.(mm)	Cv	Dimensions, in.(mm)				
	Inlet	Outlet			L1	L2	C	D	H
NG□□-NS2-5	1/8 Male NPT	1/8 Male NPT	0.08 (2.0)	0.09	0.75 (19.05)	0.75 (19.05)	0.32 (8.2)	1.00 (25.4)	2.30 (58.4)
NG□□-FNS2-5	1/8 Female NPT	1/8 Female NPT			0.81 (20.6)	0.81 (20.6)			
NG□□-FL2-5	1/8" FITOK	1/8" FITOK			0.98 (25.0)	0.98 (25.0)			
NG□□-ML3-5	3 mm FITOK	3 mm FITOK							
NG□□-FNS2-7	1/8 Female NPT	1/8 Female NPT	0.16 (4.0)	0.35	0.81 (20.6)	0.81 (20.6)	0.39 (10.0)	1.38 (35.0)	2.46 (62.5)
NG□□-NS4-7	1/4 Male NPT	1/4 Male NPT			0.98 (25.0)	0.98 (25.0)			
NG□□-FL4-7	1/4" FITOK	1/4" FITOK			1.13 (28.7)	1.13 (28.7)			
NG□□-ML6-7	6 mm FITOK	6 mm FITOK			1.17 (29.7)	1.17 (29.7)			
NG□□-ML8-7	8 mm FITOK	8 mm FITOK			2.24 (57.0)	2.24 (57.0)			
NG□□-UMB6-7	6 mm UMB	6 mm UMB							
NG□□-FNS4-8	1/4 Female NPT	1/4 Female NPT	0.25 (6.4)	0.70	1.06 (26.9)	1.06 (26.9)	0.49 (12.5)	1.88 (47.8)	2.85 (72.4)
NG□□-FNS6-8	3/8 Female NPT	3/8 Female NPT				0.62 (15.8)	2.90 (73.7)		
NG□□-NS6-8	3/8 Male NPT	3/8 Male NPT			1.12 (28.4)	1.12 (28.4)	0.49 (12.5)		2.85 (72.4)
NG□□-NS8-8	1/2 Male NPT	1/2 Male NPT			1.50 (38.1)	1.50 (38.1)	0.62 (15.8)		2.90 (73.7)
NG□□-FL6-8	3/8" FITOK	3/8" FITOK			1.29 (32.8)	1.29 (32.8)	0.49 (12.5)		2.85 (72.4)
NG□□-FL8-8	1/2" FITOK	1/2" FITOK			1.40 (35.6)	1.40 (35.6)			
NG□□-ML10-8	10 mm FITOK	10 mm FITOK			1.30 (33.0)	1.30 (33.0)			
NG□□-ML12-8	12 mm FITOK	12 mm FITOK			1.40 (35.6)	1.40 (35.6)			
NG□□-ML14-8	14 mm FITOK	14 mm FITOK			1.56 (39.7)	1.56 (39.7)	0.62 (15.8)		2.90 (73.7)
NG□□-MS20-8	M20 x 1.5 Male Metric	M20 x 1.5 Male Metric			1.50 (38.1)	1.50 (38.1)			
NG□□-UMB10-8	10 mm UMB	10 mm UMB			0.49 (12.5)	2.85 (72.4)			
NG□□-UMB14-8	14 mm UMB	14 mm UMB	2.60 (66.0)	2.60 (66.0)					

Dimensions of NG Series

Basic Ordering Number	Connection Type and Size		Orifice in.(mm)	Cv	Dimensions, in.(mm)				
	Inlet	Outlet			L1	L2	C	D	H
NG□□-FNS8-9-L	1/2 Female NPT	1/2 Female NPT	0.39 (10.0)	1.80	1.50 (38.1)	1.50 (38.1)	0.76 (19.4)	3.50 (88.9)	3.37 (85.7)
NG□□-FNS12-9-L	3/4 Female NPT	3/4 Female NPT			1.56 (39.7)	1.56 (39.7)	0.80 (20.4)		
NG□□-NS12-9-L	3/4 Male NPT	3/4 Male NPT			1.56 (39.7)	1.56 (39.7)	0.76 (19.4)		
NG□□-FL8-9-L	1/2" FITOK	1/2" FITOK							
NG□□-FL12-9-L	3/4" FITOK	3/4" FITOK			1.90 (48.3)	1.90 (48.3)	0.76 (19.4)		
NG□□-ML14-9-L	14 mm FITOK	14 mm FITOK							

1. Connection type of "FITOK" means FITOK double ferrule tube fittings. When the connection type of valves is FITOK double ferrule tube fitting, the working pressures of the valves are related to the wall thickness of used tubing. For specific working pressure of the valves, please refer to the allowable working pressures in FITOK Catalog Tubing.
2. Connection type of "UMB" means rotatable metric tube butt weld.
3. Sizes and types listed are standard. Other sizes and types are available upon request. For details, please contact FITOK Group or our authorized distributors.
4. Dimensions are shown with FITOK tube fitting nuts finger-tight. All dimensions are for reference only and are subject to change. For dimensions not shown above, please contact FITOK Group or our authorized distributors.

Panel Mount Dimensions of NG Series

Orifice in.(mm)	Dimensions, in.(mm)	
	E	F
0.08 (2.0)	0.44 (11.2)	0.47 (11.9)
0.16 (4.0)	0.44 (11.2)	0.53 (13.5)
0.25 (6.4)	0.50 (12.7)	0.78 (19.8)
0.39 (10.0)	0.75 (19.1)	1.03 (26.2)

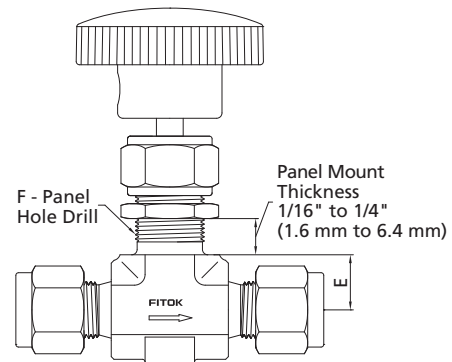

1. NG Series Needle Valves are standard without panel mounting.
2. To order needle valves with panel mounting as illustrated, add -Y to the ordering number. Example: NGSS-NS2-5-Y

Straight Pattern

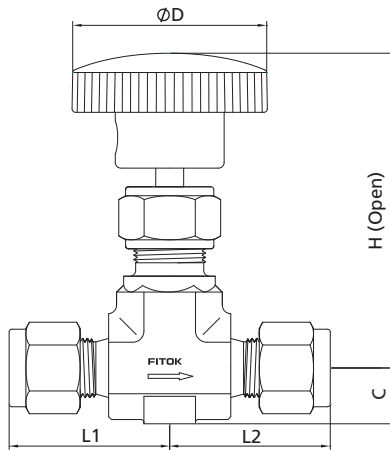

Angle Pattern

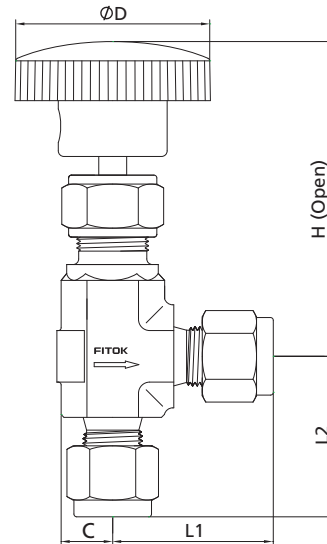

Dimensions of NGH Series

Basic Ordering Number	Connection Type and Size		Orifice in.(mm)	Cv	Dimensions, in.(mm)				
	Inlet	Outlet			L1	L2	C	D	H
NGH□□-NS2-5	1/8 Male NPT	1/8 Male NPT	0.08 (2.0)	0.09	0.75 (19.0)	0.75 (19.0)	0.32 (8.2)	1.00 (25.4)	2.30 (58.4)
NGH□□-FNS2-5	1/8 Female NPT	1/8 Female NPT			0.81 (20.6)	0.81 (20.6)			
NGH□□-FL2-5	1/8" FITOK	1/8" FITOK			0.98 (25.0)	0.98 (25.0)			
NGH□□-ML3-5	3 mm FITOK	3 mm FITOK							
NGH□□-FNS2-7	1/8 Female NPT	1/8 Female NPT	0.16 (4.0)	0.35	0.81 (20.6)	0.81 (20.6)	0.39 (10.0)	1.38 (35.0)	2.46 (62.5)
NGH□□-NS4-7	1/4 Male NPT	1/4 Male NPT			0.98 (25.0)	0.98 (25.0)			
NGH□□-FL4-7	1/4" FITOK	1/4" FITOK			1.13 (28.7)	1.13 (28.7)			
NGH□□-ML6-7	6 mm FITOK	6 mm FITOK			1.17 (29.7)	1.17 (29.7)			
NGH□□-ML8-7	8 mm FITOK	8 mm FITOK			2.24 (57.0)	2.24 (57.0)			
NGH□□-UMB6-7	6 mm UMB	6 mm UMB							
NGH□□-FNS4-8	1/4 Female NPT	1/4 Female NPT	0.25 (6.4)	0.70	1.06 (26.9)	1.06 (26.9)	0.49 (12.5)	1.88 (47.8)	2.85 (72.4)
NGH□□-FNS6-8	3/8" Female NPT	3/8" Female NPT			1.12 (28.4)	1.12 (28.4)	0.62 (15.8)		2.90 (73.7)
NGH□□-NS6-8	3/8 Male NPT	3/8 Male NPT			1.12 (28.4)	1.12 (28.4)	0.49 (12.5)		2.85 (72.4)
NGH□□-NS8-8	1/2 Male NPT	1/2 Male NPT			1.50 (38.1)	1.50 (38.1)	0.62 (15.8)		2.90 (73.7)
NGH□□-FL6-8	3/8" FITOK	3/8" FITOK			1.29 (32.8)	1.29 (32.8)	0.49 (12.5)		2.85 (72.4)
NGH□□-FL8-8	1/2" FITOK	1/2" FITOK			1.40 (35.6)	1.40 (35.6)			
NGH□□-ML10-8	10 mm FITOK	10 mm FITOK			1.30 (33.0)	1.30 (33.0)			
NGH□□-ML12-8	12 mm FITOK	12 mm FITOK			1.40 (35.6)	1.40 (35.6)			
NGH□□-ML14-8	14 mm FITOK	14 mm FITOK			1.56 (39.7)	1.56 (39.7)	0.62 (15.8)		2.90 (73.7)
NGH□□-MS20-8	M20 x 1.5 Male Metric	M20 x 1.5 Male Metric			1.50 (38.1)	1.50 (38.1)			
NGH□□-UMB10-8	10 mm UMB	10 mm UMB			0.49 (12.5)	2.85 (72.4)			
NGH□□-UMB14-8	14 mm UMB	14 mm UMB	2.60 (66.0)	2.60 (66.0)					

Dimensions of NGH Series

Basic Ordering Number	Connection Type and Size		Orifice in.(mm)	Cv	Dimensions, in.(mm)				
	Inlet	Outlet			L1	L2	C	D	H
NGH□□-FNS8-9-L	1/2 Female NPT	1/2 Female NPT	0.39 (10.0)	1.80	1.50 (38.1)	1.50 (38.1)	0.76 (19.4)	3.50 (88.9)	3.37 (85.7)
NGH□□-NS12-9-L	3/4 Male NPT	3/4 Male NPT			1.56 (39.7)	1.56 (39.7)	0.76 (19.4)		
NGH□□-FL8-9-L	1/2" FITOK	1/2" FITOK			1.90 (48.3)	1.90 (48.3)	0.76 (19.4)		
NGH□□-FL12-9-L	3/4" FITOK	3/4" FITOK							
NGH□□-ML14-9-L	14 mm FITOK	14 mm FITOK							

1. Connection type of "FITOK" means FITOK double ferrule tube fittings. When the connection type of valves is FITOK double ferrule tube fitting, the working pressures of the valves are related to the wall thickness of tubing applied. For specific working pressure of the valves, please refer to the allowable working pressures in FITOK Catalog Tubing.
2. Connection type of "UMB" means rotatable metric tube butt weld.
3. Sizes and types listed are standard. Other sizes and types are available upon request. For details, please contact FITOK Group or our authorized distributors.
4. Dimensions are shown with FITOK tube fitting nuts finger-tight. All dimensions are for reference only and are subject to change. For dimensions not shown above, please contact FITOK Group or our authorized distributors.

Needle Valves
Metering Valves

Panel Mount Dimensions of NGH Series

Orifice in.(mm)	Dimensions, in.(mm)	
	E	F
0.08 (2.0)	0.44 (11.2)	0.47 (11.9)
0.16 (4.0)	0.44 (11.2)	0.53 (13.5)
0.25 (6.4)	0.50 (12.7)	0.78 (19.8)
0.39 (10.0)	0.75 (19.1)	1.03 (26.2)

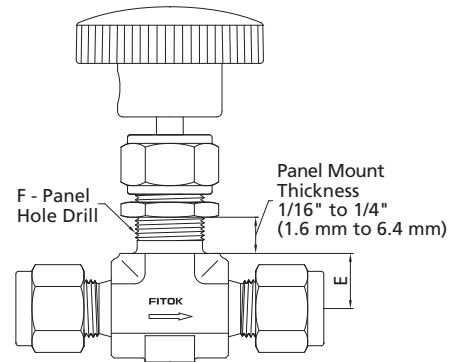

1. NGH Series Needle Valves are standard without panel mounting.
2. To order needle valves with panel mounting as illustrated, add -Y to the ordering number. Example: NGHSS-NS2-5-Y

Ordering Number Description

NGS4 - FNS8 - FL8 - 9P - PYM - ASF2

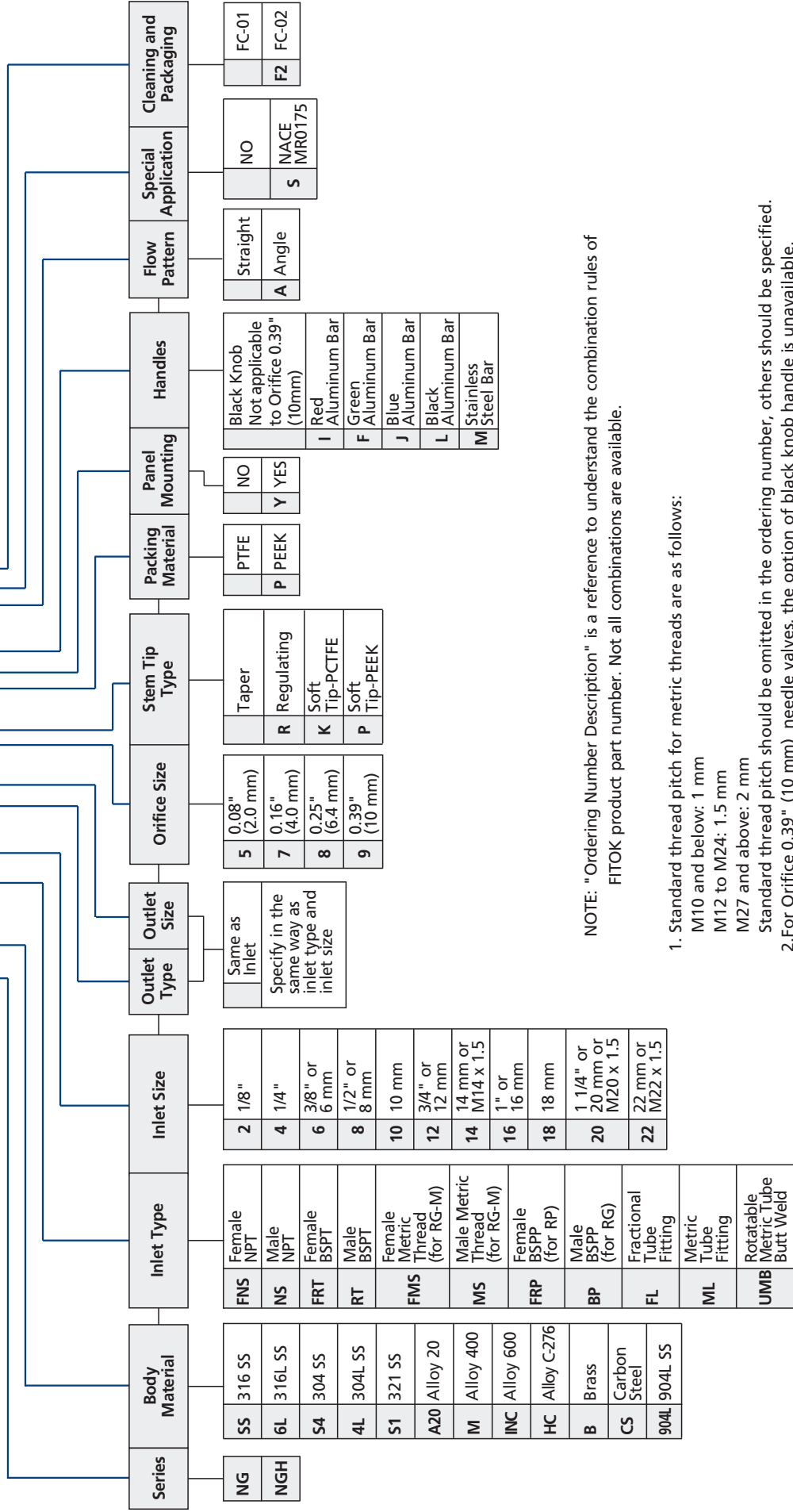

NOTE: "Ordering Number Description" is a reference to understand the combination rules of FITOK product part number. Not all combinations are available.

- Standard thread pitch for metric threads are as follows:
 M10 and below: 1 mm
 M12 to M24: 1.5 mm
 M27 and above: 2 mm
 Standard thread pitch should be omitted in the ordering number, others should be specified.
 2. For Orifice 0.39" (10 mm) needle valves, the option of black knob handle is unavailable.
 If handle designator is void, a black anodized Aluminum bar handle should be equipped.
- Cleaning and Packaging:
 FC-01: Standard cleaning and packaging for general industrial procedures.
 FC-02: Special cleaning and packaging for wetted system components to ensure compliance with product cleanliness requirement of ASTM G93 Level C.

Rising Plug Valves

NR Series NRG (with gauge port) Series

Features

- ⦿ Cold drawn square bar as body material
- ⦿ Nonrotating stem for longer seat life
- ⦿ Roddable, straight through flow path for maximum flow with minimum pressure drop
- ⦿ Stem thread lubricant isolated from system media
- ⦿ Replaceable seat and stem tip design
- ⦿ Stem thread protected from outside contamination by PTFE ring in the gland
- ⦿ Panel mounting available
- ⦿ Handles of different colors available
- ⦿ Every valve leak tested with Nitrogen or compressed air at the maximum allowable working pressure
- ⦿ Working pressure up to:
 - Stainless steel: 6000 psig (414 bar)
 - Alloy 400: 5000 psig (345 bar)
- ⦿ Working temperature with seat:
 - Acetal: -20°F to 250°F (-28°C to 121°C)
 - PEEK: -20°F to 450°F (-28°C to 232°C)
- ⦿ Working temperature with O-ring:
 - Fluorocarbon Rubber (FKM): -20°F to 400°F (-28°C to 204°C)
 - Nitrile Butadiene Rubber (NBR): -20°F to 212°F (-28°C to 100°C)
 - Ethylene Propylene Diene Rubber (EPDM): -20°F to 300°F (-28°C to 148°C)



Needle Valves
Metering Valves

Pressure vs. Temperature

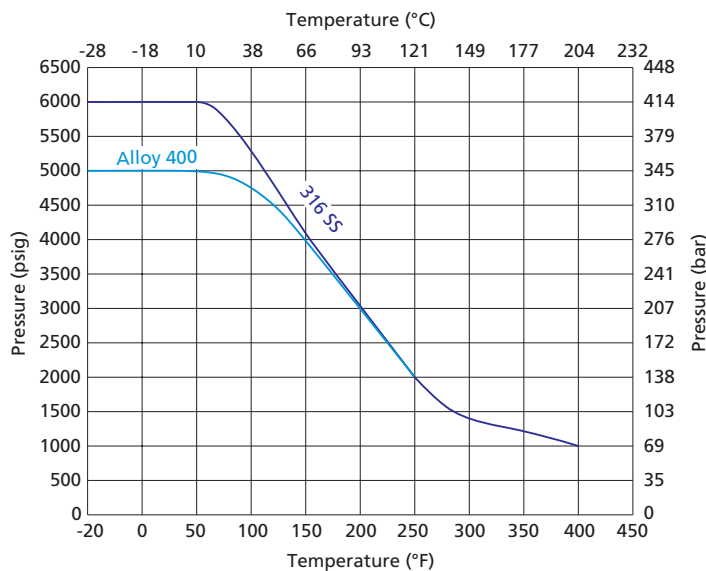

Flow Data at 100°F (38°C)

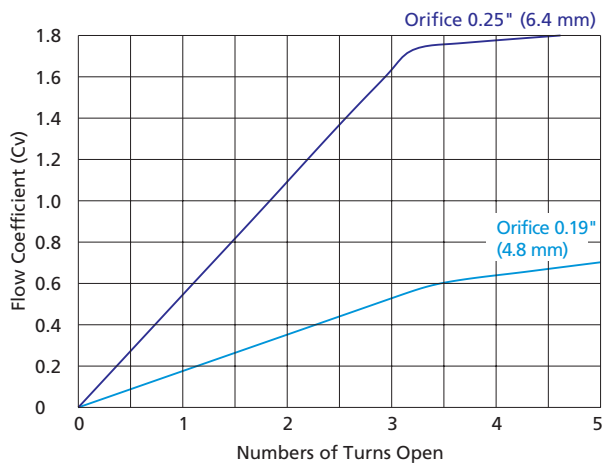

1. Graphs are based on PEEK seat and Fluorocarbon(FKM) O-ring.
2. Contact FITOK Group or our authorized distributors for curve graph of other materials.

Standard Materials of Construction

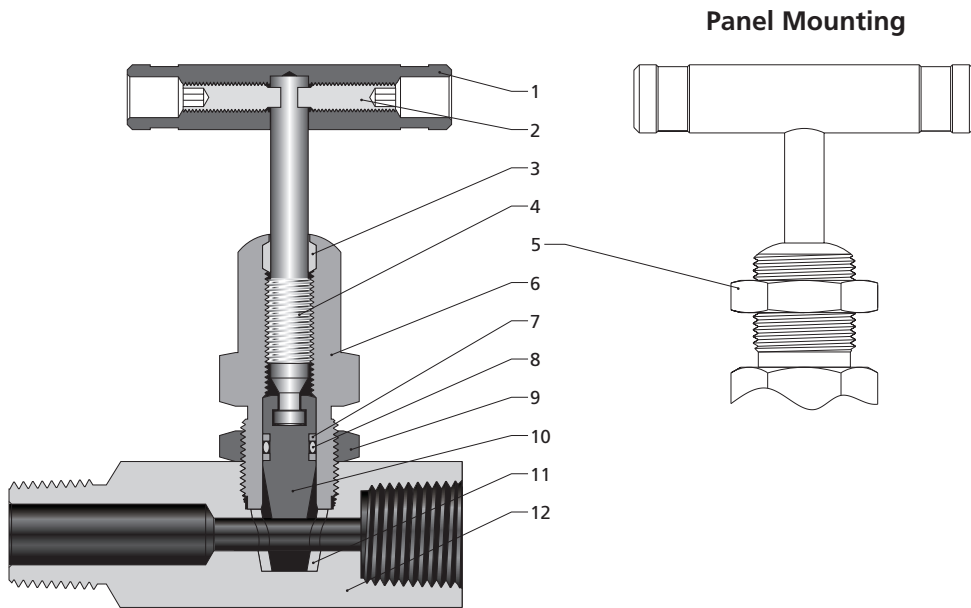

Item	Component	Valve Body Material			
		316 SS	304 SS	321 SS	Alloy 400
		Material Grade/ASTM Specification			
1	Handle	Anodized aluminum or stainless steel or black knob			
2	Set Screw	Galvanized carbon steel			
3	Wiper Ring	PTFE/D1710			
4	Upper Stem	316 SS/A479			Alloy 400/B164
5	Panel Nut	Stainless steel			
6	Bonnet	316 SS/A479	304 SS/A479	321 SS/A479	Alloy 400/B164
7	Backup Ring	PTFE/D1710			
8	O-ring	Fluorocarbon Rubber (FKM), Nitrile Butadiene Rubber (NBR) or Ethylene Propylene Diene Rubber (EPDM)			
9	Lock Nut	Stainless steel			
10	Stem Tip	316 SS/A479	304 SS/A479	321 SS/A479	Alloy 400/B164
11	Seat	Acetal or PEEK			
12	Body	316 SS/A479	304 SS/A479	321 SS/A479	Alloy 400/B164
	Lubricant	Molybdenum disulfide-based			

Note: Contact FITOK Group or our authorized distributors for other materials.

Dimensions

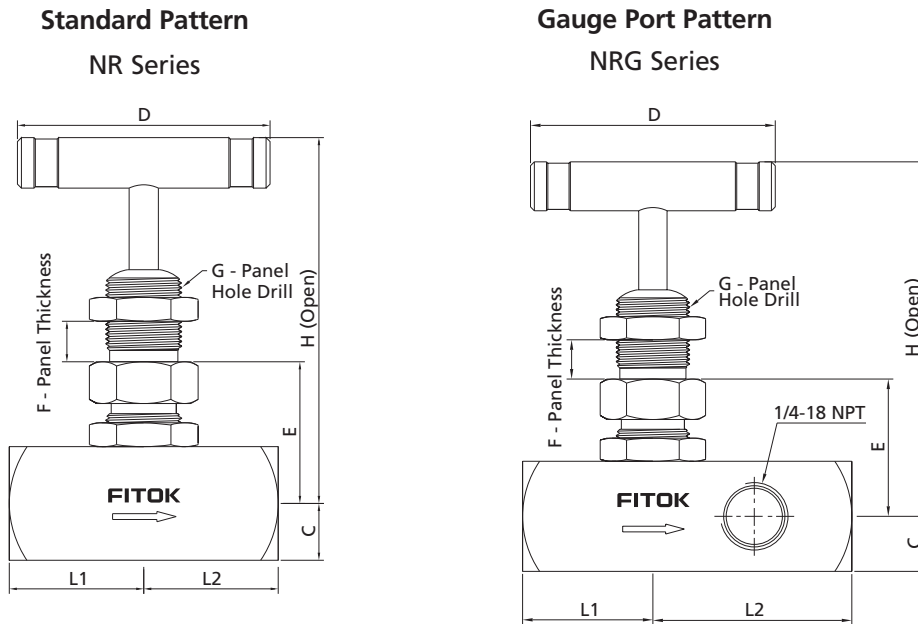

Ⓞ NR Series Needle Valves are standard without panel mounting. To order needle valves with panel mounting as illustrated, add -Y to the ordering number. Example: NRSS-FNS4-7-Y

Dimensions of NR and NRG Series

Basic Ordering Number	Connection Type and Size		Orifice in.(mm)	Cv	Dimensions, in.(mm)							
	Inlet	Outlet			L1	L2	C	D	E	F	G	H
NR □□-FNS4-7	1/4 Female NPT	1/4 Female NPT	0.19 (4.8)	0.63	1.12 (28.4)	1.12 (28.4)	0.44 (11.1)	2.17 (55.0)	1.34 (34.0)	0.38 (9.7)	0.77 (19.6)	3.77 (95.8)
NR □□-NS4-FNS4-7	1/4 Male NPT	1/4 Female NPT			1.78 (45.2)							
NR □□-NS8-FNS4-7	1/2 Male NPT	1/4 Female NPT			1.89 (48.0)							
NRG □□-FNS4-7	1/4 Female NPT	1/4 Female NPT			1.12 (28.4)	1.75 (44.4)						
NRG □□-NS8-FNS4-7	1/2 Male NPT	1/4 Female NPT			3.12 (79.2)							
NR □□-FNS8-8	1/2 Female NPT	1/2 Female NPT	0.25 (6.4)	1.80	1.33 (33.8)	1.33 (33.8)	0.56 (14.3)	2.50 (63.5)	1.40 (35.5)	0.38 (9.7)	0.77 (19.6)	3.83 (97.3)
NR □□-NS8-FNS8-8	1/2 Male NPT	1/2 Female NPT			2.16 (54.9)							
NR □□-NS12-FNS8-8	3/4 Male NPT	1/2 Female NPT			3.33 (84.6)							
NRG □□-FNS8-8	1/2 Female NPT	1/2 Female NPT			3.33 (84.6)	2.25 (57.2)						
NRG □□-NS12-FNS8-8	3/4 Male NPT	1/2 Female NPT										

1. Sizes and types listed are standard. Other sizes and types are available upon request.
2. For dimensions not shown above, please contact FITOK Group or our authorized distributors.

Ordering Number Description

NRSS - NS8 - FNS8 - P8 - BYM - SF2

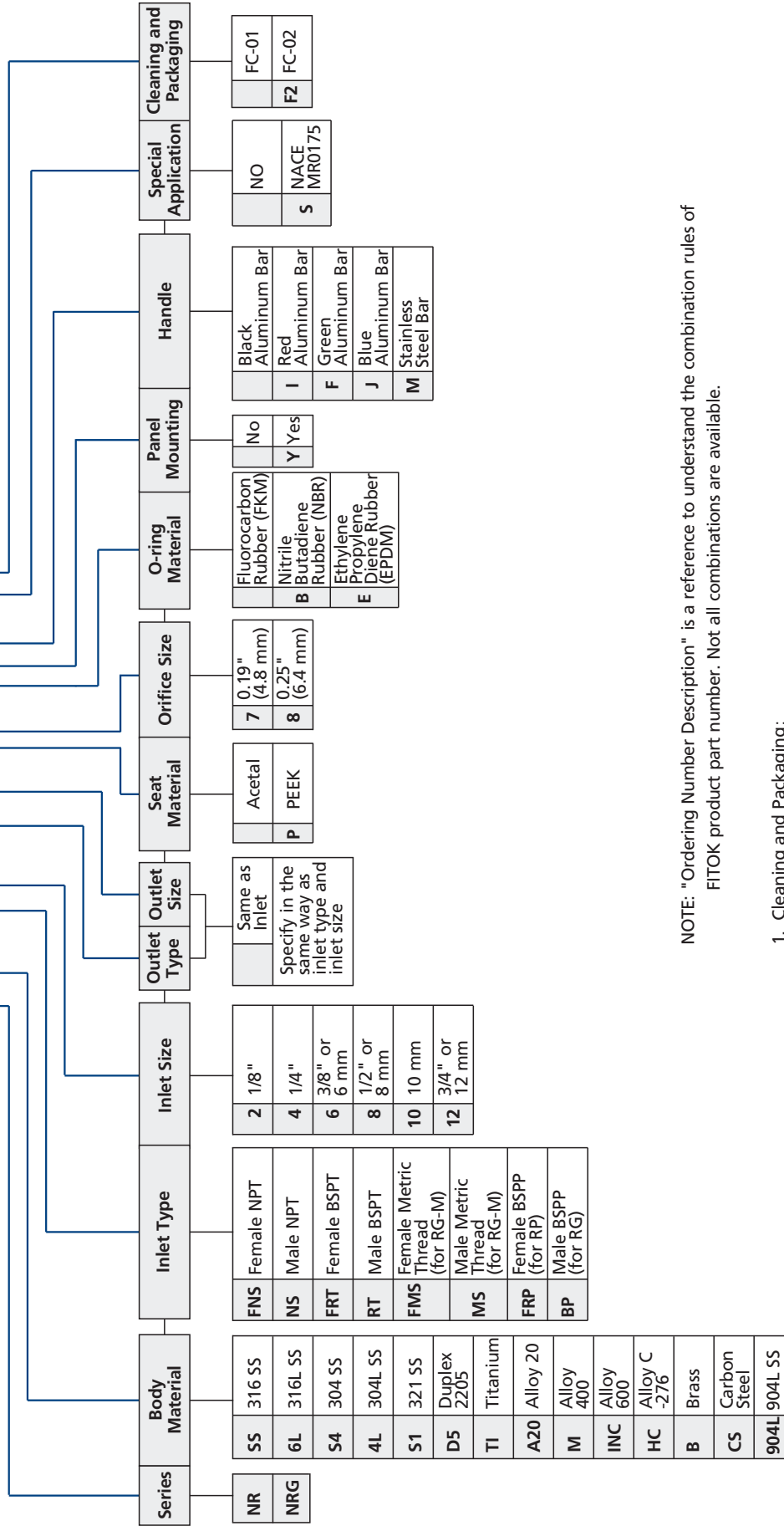

NOTE: "Ordering Number Description" is a reference to understand the combination rules of FITOK product part number. Not all combinations are available.

- Cleaning and Packaging:
 - FC-01: Standard cleaning and packaging for general industrial procedures.
 - FC-02: Special cleaning and packaging for wetted system components to ensure compliance with product cleanliness requirement of ASTM G93 Level C.

Toggle Valves

NT Series

Features

- ⦿ One piece forged body
- ⦿ Straight and angle patterns
- ⦿ Compact design
- ⦿ Quick opening or closing
- ⦿ Nonrotating stem
- ⦿ Panel mounting available
- ⦿ Every valve leak tested with Nitrogen or compressed air at the maximum allowable working pressure
- ⦿ Working pressure up to: 300 psig (20.7 bar)



Technical Data

Orifice in. (mm)	Working Pressure at 100°F (38°C) psig (bar)	O-ring Material	Temperature Rating
0.08 (2.0)	300 (20.7)	Fluorocarbon Rubber (FKM)	-20°F to 400°F (-28°C to 204°C)
0.125 (3.2)		Nitrile Butadiene Rubber (NBR)	-20°F to 212°F (-28°C to 100°C)
0.25 (6.4)	200 (13.8)	Ethylene Propylene Diene Rubber (EPDM)	-20°F to 300°F (-28°C to 148°C)

Standard Materials of Construction

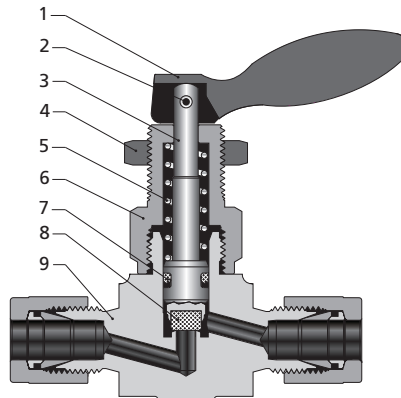

Item	Component	Valve Body Material			
		316 SS	304 SS	321 SS	Brass
		Material Grade/ASTM Specification			
1	Handle	Stainless steel			
2	Pin	Stainless steel			
3	Stem	316 SS/A479	304 SS/A479		316 SS/A479
4	Panel Nut	Stainless steel			Brass C36000/B16
5	Spring	S17700/A313			
6	Bonnet	304 SS/A479			Brass C36000/B16
7	O-ring	Fluorocarbon Rubber (FKM), Nitrile Butadiene Rubber (NBR) or Ethylene Propylene Diene Rubber (EPDM)			
8	Stem Tip	PTFE/D1710			
9	Body	316 SS/A182	304 SS/A182	321 SS/A182	Brass C37700/B283
Lubricant		Molybdenum disulfide-based			

Note: Contact FITOK Group or our authorized distributors for other materials.

Dimensions

Straight Pattern

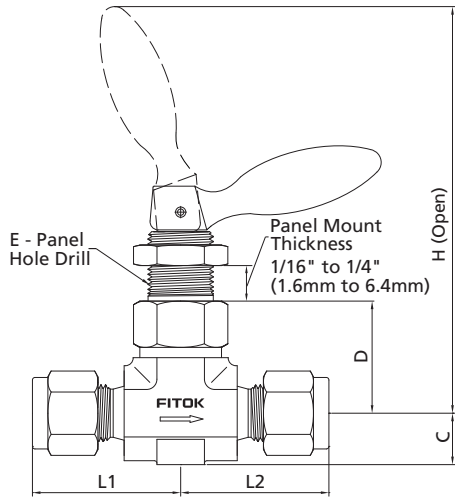

Angle Pattern

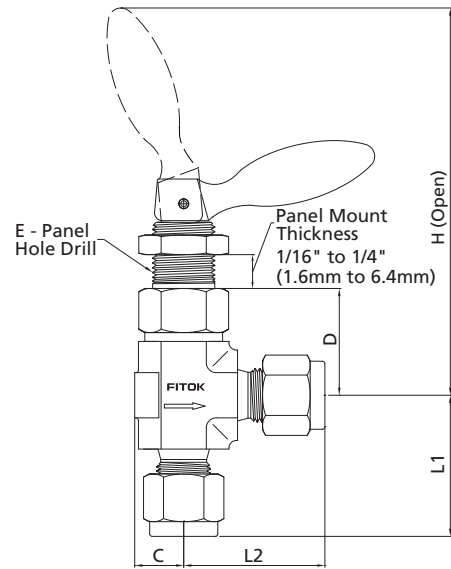

Dimensions of NT series

Basic Ordering Number	Connection Type and Size		Orifice in.(mm)	Cv	Dimensions, in.(mm)					
	Inlet	Outlet			L1	L2	C	D	E	H
NT□□-NS2-5	1/8 Male NPT	1/8 Male NPT	0.08 (2.0)	0.11	0.75 (19.05)	0.75 (19.05)	0.32 (8.2)	0.85 (21.7)	0.53 (13.5)	2.83 (71.9)
NT□□-NS2-FL2-5	1/8 Male NPT	1/8" FITOK			0.75 (19.05)	0.98 (25.0)				
NT□□-FL2-5	1/8" FITOK	1/8" FITOK			0.98 (25.0)	0.98 (25.0)				
NT□□-ML3-5	3 mm FITOK	3 mm FITOK								
NT□□-FNS2-7	1/8 Female NPT	1/8 Female NPT	0.125 (3.2)	0.20	0.81 (20.6)	0.81 (20.6)	0.39 (10.0)	0.85 (21.7)	0.53 (13.5)	2.83 (71.9)
NT□□-NS2-7	1/8 Male NPT	1/8 Male NPT			0.86 (21.8)	0.86 (21.8)				
NT□□-NS4-7	1/4 Male NPT	1/4 Male NPT			0.98 (25.0)	0.98 (25.0)				
NT□□-NS4-FL4-7	1/4 Male NPT	1/4" FITOK			0.98 (25.0)	1.13 (28.7)				
NT□□-FL4-7	1/4" FITOK	1/4" FITOK								
NT□□-ML6-7	6 mm FITOK	6 mm FITOK			1.13 (28.7)					
NT□□-ML8-7	8 mm FITOK	8 mm FITOK								
NT□□-FNS4-8	1/4 Female NPT	1/4 Female NPT			0.25 (6.4)	0.70				
NT□□-FNS6-8	3/8 Female NPT	3/8 Female NPT	1.12 (28.4)	1.12 (28.4)						
NT□□-NS6-8	3/8 Male NPT	3/8 Male NPT	1.29 (32.8)	1.29 (32.8)						
NT□□-FL6-8	3/8" FITOK	3/8" FITOK	1.40 (35.6)	1.40 (35.6)						
NT□□-FL8-8	1/2" FITOK	1/2" FITOK	1.36 (34.5)	1.36 (34.5)						
NT□□-ML10-8	10 mm FITOK	10 mm FITOK	1.46 (37.1)	1.46 (37.1)						
NT□□-ML12-8	12 mm FITOK	12 mm FITOK								

1. Connection type of "FITOK" means FITOK double ferrule tube fittings.
2. Sizes and types listed are standard. Other sizes and types are available upon request. For details, please contact FITOK Group or our authorized distributors.
3. Dimensions are shown with FITOK tube fitting nuts finger-tight. All dimensions are for reference only and are subject to change. For dimensions not shown above, please contact FITOK Group or our authorized distributors.

Pneumatic Actuators

Features

- Valve and actuator are fully assembled and every valve leak tested with Nitrogen or compressed air at the maximum allowable working pressure
- Opens and closes quickly and reliably
- Rotatable actuator port allows easy installation

Actuation Modes

- Normally closed—air opens, spring closes
- Normally open—air closes, spring opens
- Double acting—air opens and closes

Normally Closed and Double Acting

Normally Open



Technical Data

Actuator Type	Working Pressure at 100°F (38°C) psig (bar)	Actuator Pressure Rating psig (bar)
Normally closed	300 (20.7)	87 (6)
Normally open	450 (31.0)	
Double acting		

Component	Material
	Material Grade/ASTM Specification
Housing	Anodized aluminum
Spring	S17700/A313
Mounting Bracket	304SS/A240
Stem Tip	Normally open, normally closed—PTFE/D1710, double acting—PCTFE/D1430

Please refer to NT Series "Standard Materials of Construction" for other materials.

Dimensions

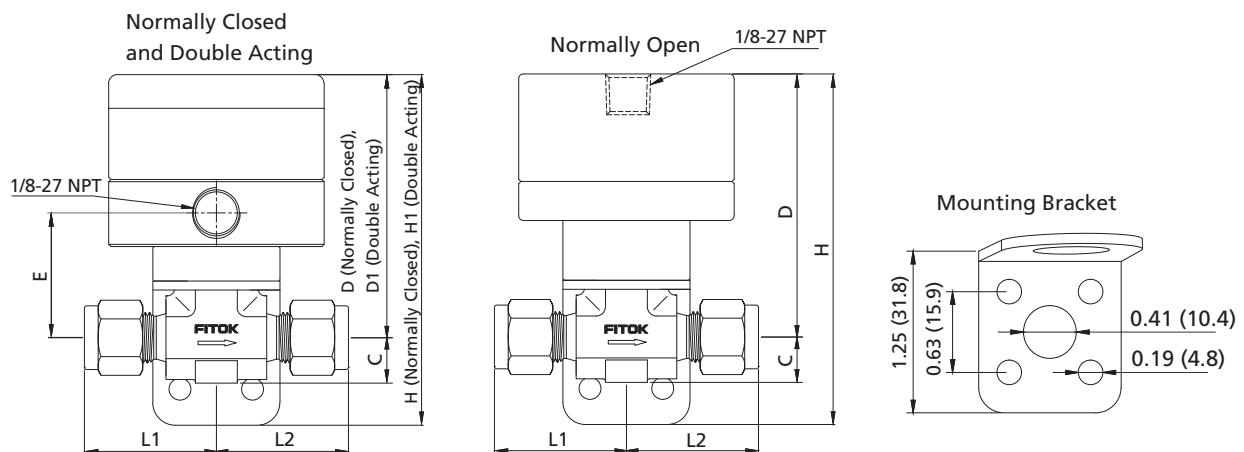

Basic Ordering Number	Connection Type and Size		Orifice in.(mm)	Cv	Dimensions, in.(mm)							
	Inlet	Outlet			L1	L2	C	D	D1	H	H1	E
NT□□-NS2-5-C-Y	1/8 Male NPT	1/8 Male NPT	0.08 (2.0)	0.11	0.86 (21.8)	0.86 (21.8)						
NT□□-NS2-FL2-5-C-Y	1/8 Male NPT	1/8" FITOK			0.86 (21.8)	1.03 (26.2)						
NT□□-FL2-5-C-Y	1/8" FITOK	1/8" FITOK			1.03 (26.2)	1.03 (26.2)						
NT□□-ML3-5-C-Y	3 mm FITOK	3 mm FITOK	0.125 (3.2)	0.20	0.81 (20.6)	0.81 (20.6)	0.39 (10.0)	2.28 (58)	2.46 (62.5)	3.04 (77.3)	3.22 (81.8)	1.08 (27.5)
NT□□-FNS2-7-C-Y	1/8 Female NPT	1/8 Female NPT			0.86 (21.8)	0.86 (21.8)						
NT□□-NS2-7-C-Y	1/8 Male NPT	1/8 Male NPT			0.98 (25.0)	0.98 (25.0)						
NT□□-NS4-7-C-Y	1/4 Male NPT	1/4 Male NPT			0.98 (25.0)	0.98 (25.0)						
NT□□-NS4-FL4-7-C-Y	1/4 Male NPT	1/4" FITOK			1.13 (28.7)	1.13 (28.7)						
NT□□-FL4-7-C-Y	1/4" FITOK	1/4" FITOK										
NT□□-ML6-7-C-Y	6 mm FITOK	6 mm FITOK										
NT□□-ML8-7-C-Y	8 mm FITOK	8 mm FITOK										

1. Connection type of "FITOK" means FITOK double ferrule tube fittings.
2. Sizes and types listed are standard. Other sizes and types are available upon request. For details, please contact FITOK Group or our authorized distributors.
3. Dimensions are shown with FITOK tube fitting nuts finger-tight. All dimensions are for reference only and are subject to change. For dimensions not shown above, please contact FITOK Group or our authorized distributors.

Ordering Number Description

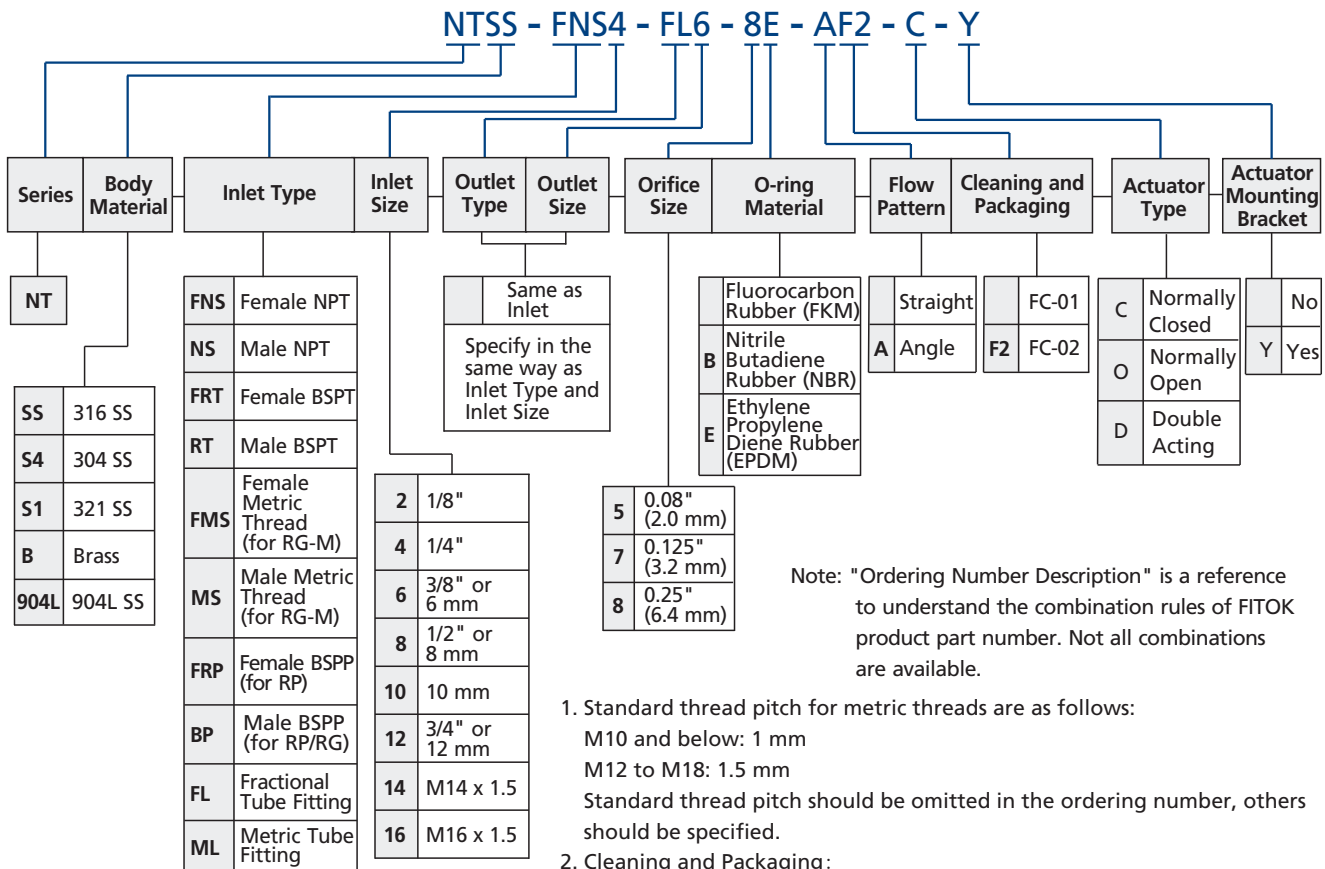

1. Standard thread pitch for metric threads are as follows:
 M10 and below: 1 mm
 M12 to M18: 1.5 mm
 Standard thread pitch should be omitted in the ordering number, others should be specified.
2. Cleaning and Packaging:
 FC-01: Standard cleaning and packaging for general industrial procedures.
 FC-02: Special cleaning and packaging for wetted system components to ensure compliance with product cleanliness requirement of ASTM G93 Level C.

Union Bonnet Needle Valves

NU Series: Working pressure up to 6000 psig

NUH Series: Working pressure up to 10000 psig

Features

- ⦿ One-piece forged body
- ⦿ Two-piece stem design: Upper stem threads cold rolled and lower stem hardened for high strength and smooth operation
- ⦿ Accidental valve disassembly disabled by union bonnet construction
- ⦿ Upper stem thread lubricant isolated from system media
- ⦿ Linear instead of rotary movement of the rising, non-rotating stem minimizes packing abrasion and reduces the friction between the seat and the tip
- ⦿ Safety back seating seal in fully open position
- ⦿ Panel mounting available
- ⦿ Steady and durable fastening of the handle by double lock-pins
- ⦿ Handles of different colors available
- ⦿ Every valve leak tested with Nitrogen or compressed air (NU Series) at the maximum allowable working pressure or with water (NUH Series) at 1.1 times the maximum allowable pressure
- ⦿ Working pressure up to:
 - NU Series—Stainless steel: 6000 psig (414 bar)
 - Alloy C-276: 6000 psig (414 bar)
 - Alloy 400: 5000 psig (345 bar)
 - Titanium: 3500 psig (241 bar)
 - NUH Series—Stainless steel: 10000 psig (690 bar)
- ⦿ Working temperature:
 - PTFE: -65°F to 450°F (-54°C to 232°C)
 - PEEK: -65°F to 500°F (-54°C to 260°C)
 - Graphite: -65°F to 1200°F (-54°C to 649°C)



Pressure vs. Temperature

NU Series

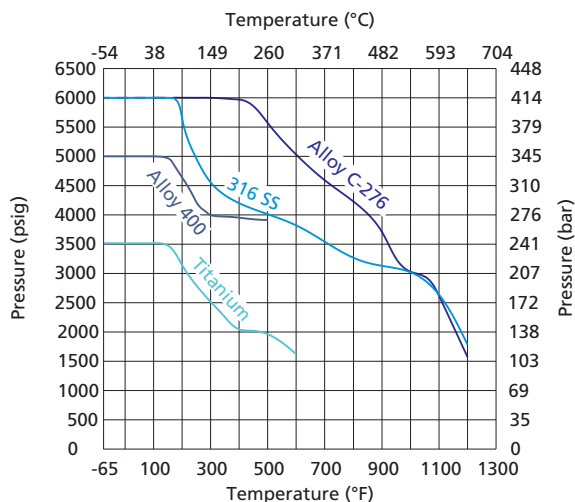

NUH Series

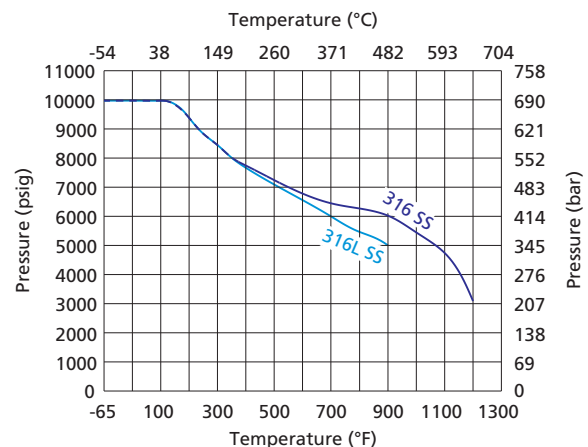

1. Graphs are based on graphite packing.
2. Soft tips are for NU Series only. Temperature rating is limited to 200°F (93°C) max. with PCTFE stem tip (soft tip).
3. Contact FITOK Group or our authorized distributors for curve graph of other materials.

Flow Data at 100°F (37°C)

Regulating Stem

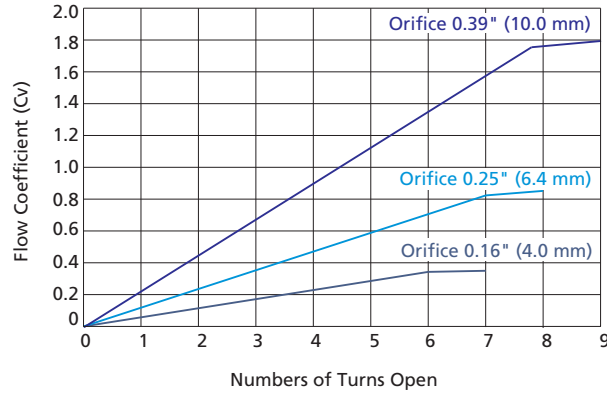

Standard Materials of Construction

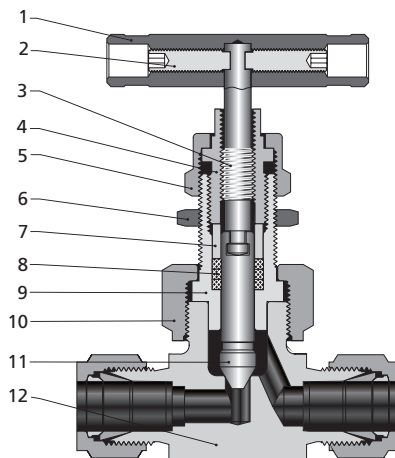

Stem Type

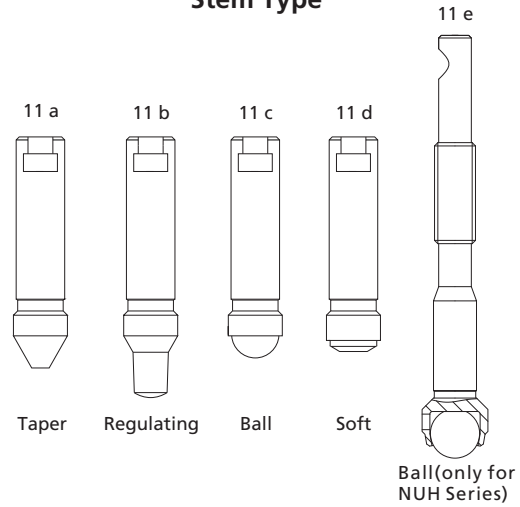

Needle Valves
Metering Valves

Item	Component	Valve Body Material			
		316 SS	Alloy 400	Titanium	Alloy C-276
		Material Grade/ASTM Specification			
1	Handle	Anodized aluminium or stainless steel or black knob			
2	Set Screw	Galvanized carbon steel			
3	Upper Stem	316 SS/A479			
4	Packing Bolt	304 SS/A479			
5	Lock Nut	316 SS/A479			
6	Panel Nut	Stainless steel			
7	Gland	316 SS/A479			
8	Packing	PTFE or PEEK or graphite			
9	Bonnet	316 SS/A479	Alloy 400/B164	Titanium Gr 4/B348	Alloy C-276/B574
10	Union Nut	316 SS/A479			
11a 11b 11c	Lower Stem	Hardened 316 SS/A479	Alloy 400/B164	Titanium Gr 4/B348	Alloy C-276/B574
11d	Stem	316 SS/A479	Alloy 400/B164	Titanium Gr 4/B348	Alloy C-276/B574
	Stem Tip	PTFE or PCTFE or PEEK			
11e	Stem	316 SS/A479	Not Applicable		Alloy C-276/B574
	Stem Tip	Stellite			
12	Body	316 SS/A182	Alloy 400/B164, B127, B564	Titanium Gr 4/B348 or titanium Gr 4/B381	Alloy C-276/B564
	Seat	Same as Body			
Lubricant		Molybdenum disulfide-based			

Note: Contact FITOK Group or our authorized distributors for other materials.

Dimensions of NU Series

Basic Ordering Number	Connection Type and Size	Connection Pressure at 100°F (38°C) psig (bar)	Orifice in.(mm)	Cv	Dimensions, in.(mm)								
					Inlet/Outlet	316 SS	L1	L2	L3	L4	C	D	E
NU□□-ML12-8	12 mm FITOK	6000 (414)	0.25 (6.4)	0.86	1.52 (38.6)	1.52 (38.6)	1.40 (35.6)	1.58 (40.1)	2.50 (63.5)	0.50 (12.7)	1.34 (34.0)	0.78 (19.8)	3.78 (96.0)
NU□□-ML14-8	14 mm FITOK												
NU□□-ML16-8	16 mm FITOK	5800 (400)											
NU□□-TS6-8-G	3/8" TS	6000 (414)											
NU□□-TS8-8-G	1/2" TS												
NU□□-PS4-8-G	1/4 PS												
NU□□-MTS12-8-G	12 mm MTS												
NU□□-MTS14-8-G	14 mm MTS												
NU□□-MTS16-8-G	16 mm MTS												
NU□□-MTB14-8-G	14 mm MTB												
NU□□-MTB16-8-G	16 mm MTB												
NU□□-UMB14-8	14 mm UMB												
NU□□-FO8-8	1/2" Male FO												
NU□□-FR8-8	1/2" Male FR												
NU□□-MS20-8	M20 x 1.5 Male Metric												
NU□□-MS22-8	M22 x 1.5 Male Metric												
NU□□-NS8-9	1/2 Male NPT	6000 (414)	0.39 (10.0)	1.8	1.56 (39.6)	1.56 (39.6)	1.56 (39.6)	1.56 (39.6)	3.50 (88.9)	0.63 (16.0)	1.82 (46.2)	1.03 (26.2)	4.76 (121)
NU□□-FNS8-9	1/2 Female NPT												
NU□□-FNS12-9	3/4 Female NPT												
NU□□-NS12-9	3/4 Male NPT												
NU□□-FL8-9	1/2" FITOK												
NU□□-FL12-9	3/4" FITOK												
NU□□-ML14-9	14 mm FITOK												
NU□□-ML16-9	16 mm FITOK												
NU□□-ML18-9	18 mm FITOK												
NU□□-ML20-9	20 mm FITOK												
NU□□-MTS14-9-G	14 mm MTS												
NU□□-MTS16-9-G	16 mm MTS												
NU□□-TS8-9-G	1/2" TS												
NU□□-TS12-9-G	3/4" TS												
NU□□-MTB16-9-G	16 mm MTB												
NU□□-UMB14-9	14 mm UMB												
NU□□-FR8-9	1/2" Male FR												
NU□□-MS27-9	M27 x 2 Male Metric												

1. Connection type of "FITOK" means FITOK double ferrule tube fittings. When the connection type of valves is FITOK double ferrule tube fitting, the working pressures of the valves are related to the wall thickness of tubing applied. For specific working pressure of the valves, please refer to the allowable working pressures in FITOK Catalog Tubing.
2. Connection type of "TS" means fractional tube socket weld. "MTS" means metric tube socket weld. "MTB" means metric tube butt weld. "UMB" means rotatable metric tube butt weld. "PS" means pipe socket weld.
4. Sizes and types listed are standard. Other sizes and types are available upon request. For details, please contact FITOK Group or our authorized distributors.
5. Dimensions are shown with FITOK tube fitting nuts finger-tight. All dimensions are for reference only and are subject to change. For dimensions not shown above, please contact FITOK Group or our authorized distributors.

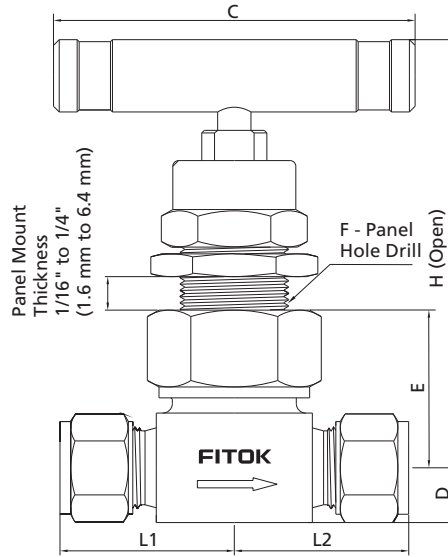

Dimensions of NUH Series

Basic Ordering Number	Connection Type and Size	Connection Pressure at 100°F (38°C) psig (bar)	Orifice in.(mm)	Cv	Dimensions, in.(mm)						
					Inlet/Outlet	316 SS	L1	L2	C	D	E
NUH□□-FL4-7	1/4" FITOK	10000 (690)	0.16 (4.0)	0.35	1.41 (35.8)	1.41 (35.8)	2.50 (63.5)	0.50 (12.7)	1.35 (34.3)	0.78 (19.8)	3.74 (95.0)
NUH□□-FNS2-7	1/8 Female NPT										
NUH□□-FNS4-7	1/4 Female NPT										
NUH□□-NS4-FNS4-7	1/4 Male NPT										
NUH□□-NS4-7	1/4 Male NPT										
NUH□□-TS4-7-G	1/4" TS										
NUH□□-FNS4-8	1/4 Female NPT		0.25 (6.4)	0.86	1.56 (39.7)	1.56 (39.7)	3.50 (88.9)	0.63 (16.0)	1.77 (45.0)	1.03 (26.2)	4.90 (124.5)
NUH□□-NS8-8	1/2 Male NPT										
NUH□□-TS8-8-G	1/2" TS										
NUH□□-MTS12-8-G	12 mm MTS										
NUH□□-MTS16-9-G	16 mm MTS										
NUH□□-MTB22-9-G	22 mm MTB										
NUH□□-FNS8-9	1/2 Female NPT	0.39 (10.0)	1.8	1.75 (44.5)	1.75 (44.5)	3.50 (88.9)	0.91 (23.0)	2.29 (58.2)	1.14 (28.9)	5.28 (134.1)	
				1.56 (39.7)	1.56 (39.7)						

1. Connection type of "FITOK" means FITOK double ferrule tube fittings. When the connection type of valves is FITOK double ferrule tube fitting, the working pressures of the valves are related to the wall thickness of tubing applied. For specific working pressure of the valves, please refer to the allowable working pressures in FITOK Tubing catalog.
2. Connection type of "TS" means fractional tube socket weld. "MTS" means metric tube socket weld. "MTB" means metric tube butt weld.
3. Sizes and types listed are standard. Other sizes and types are available upon request. For details, please contact FITOK Group or our authorized distributors.
4. Dimensions are shown with FITOK tube fitting nuts finger-tight. All dimensions are for reference only and are subject to change. For dimensions not shown above, please contact FITOK Group or our authorized distributors.

Ordering Number Description

NUSS - FNS6 - FL6 - 8WB - GM - ASF2

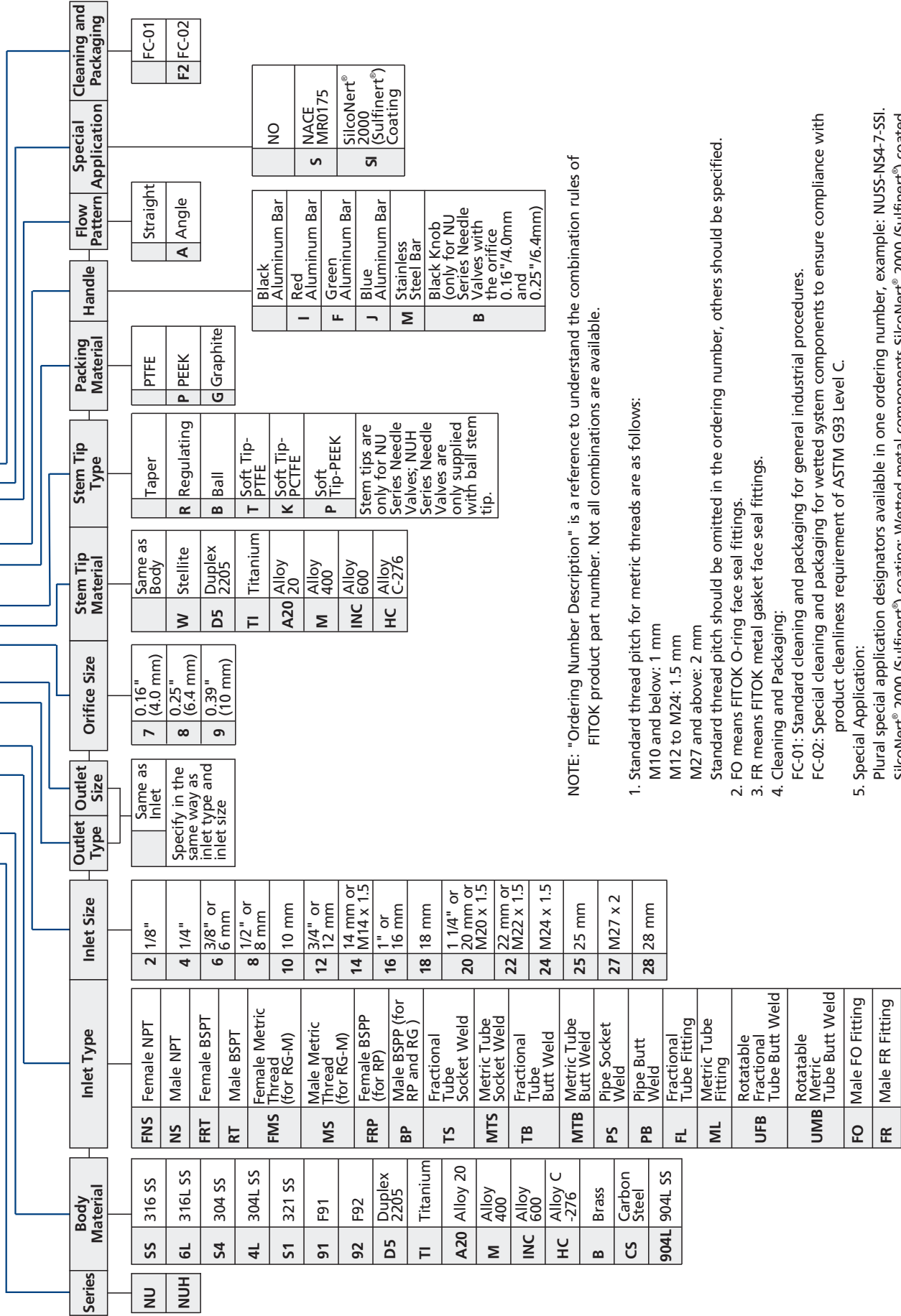

NOTE: "Ordering Number Description" is a reference to understand the combination rules of FITOK product part number. Not all combinations are available.

- Standard thread pitch for metric threads are as follows:
 M10 and below: 1 mm
 M12 to M24: 1.5 mm
 M27 and above: 2 mm
 Standard thread pitch should be omitted in the ordering number, others should be specified.
- FO means FITOK O-ring face seal fittings.
- FR means FITOK metal gasket face seal fittings.
- Cleaning and Packaging:
 FC-01: Standard cleaning and packaging for general industrial procedures.
 FC-02: Special cleaning and packaging for wetted system components to ensure compliance with product cleanliness requirement of ASTM G93 Level C.
- Special Application:
 Plural special application designators available in one ordering number, example: NUSS-NS4-7-SSI.
 SilcoNert® 2000 (Sulfinert®) coating: Wetted metal components SilcoNert® 2000 (Sulfinert®) coated.

Outside Screw and Yoke (OS&Y) Needle Valves

NY Series: Working pressure up to 6000 psig

Features

- ⦿ Cold drawn bar as body
- ⦿ Standard seat diameter 0.16" (4mm). Cv: 0.35 standard
- ⦿ Hardened stem threads prevent galling
- ⦿ Stem threads completely isolated from system media
- ⦿ Linear instead of rotary motion of the rising, non-rotating stem minimizes packing abrasion and reduces the friction between the seat and the tip
- ⦿ Externally adjustable gland, independent of spindle thread
- ⦿ Steady and durable fastening of the handle by double lock-pins
- ⦿ Bottom mounting available
- ⦿ Every valve leak tested with Nitrogen or compressed air at maximum allowable working pressure
- ⦿ Working pressure up to:
 - Stainless steel: 6000 psig (414 bar)
 - Alloy C-276: 6000 psig (414 bar)
 - Alloy 400: 5000 psig (345 bar)
- ⦿ Working temperature:
 - PTFE: -65°F to 450°F (-54°C to 232°C)
 - PEEK: -65°F to 500°F (-54°C to 260°C)
 - Graphite: -65°F to 1200°F (-54°C to 649°C)



Pressure vs. Temperature

NY Series

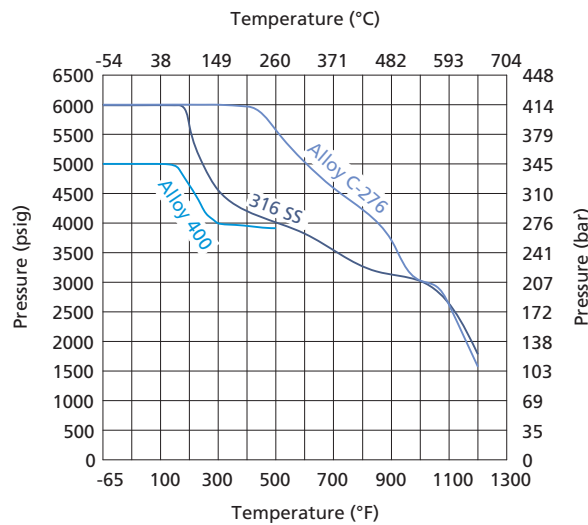

1. Graphs are based on graphite packing.
2. Contact FITOK Group or our authorized distributors for curve graph of other materials.

Standard Materials of Construction

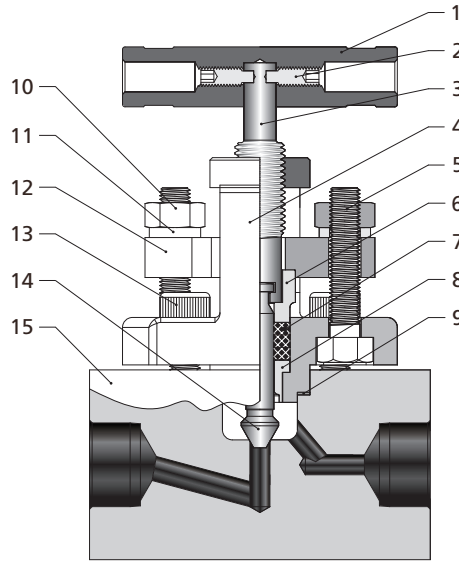

Item	Component	Valve Body Material
		316 SS
		Material Grade/ASTM Specification
1	Handle	Anodized aluminum or stainless steel
2	Set Screw	Galvanized carbon steel
3	Upper Stem	316 SS/A479
4	Yoke	316 SS/A182
5	Bolts	Stainless steel
6	Packing Washer	316 SS/A479
7	Packing	PTFE or PEEK or graphite
8	Packing Washer	316 SS/A479
9	Joint Seal	316 SS/A479
10	Nuts	Stainless steel
11	Gaskets	Stainless steel
12	Gland bridge	316 SS/A182
13	Bolts	Stainless steel
14	Lower Stem	Hardened 316 SS/A479
15	Body	316 SS/A479
	Lubricant	Molybdenum disulfide-based

Note: Contact FITOK Group or our authorized distributors for other materials.

Dimensions of NY Series

Basic Ordering Number	Connection Type and Size		Orifice in.(mm)	Cv	Dimensions, in.(mm)		
	Inlet	Outlet			A	B	C
NY□□-FNS4	1/4 Female NPT	1/4 Female NPT	0.16 (4.0)	0.35	2.69 (68.2)	1.50 (38.1)	4.04 (102.7)
NY□□-NS4	1/4 Male NPT	1/4 Male NPT			2.95 (75.0)		
NY□□-NS4-FNS4	1/4 Male NPT	1/4 Female NPT			2.72 (69.2)		
NY□□-FNS6	3/8 Female NPT	3/8 Female NPT			2.93 (75.0)		
NY□□-NS6	3/8 Male NPT	3/8 Male NPT			3.00 (76.2)		
NY□□-FNS8	1/2 Female NPT	1/2 Female NPT			3.27 (82.0)		
NY□□-NS8	1/2 Male NPT	1/2 Male NPT			3.00 (76.2)		
NY□□-NS8-FNS8	1/2 Male NPT	1/2 Female NPT			3.00 (76.2)		
NY□□-PS8-G	1/2 PS	1/2 PS			3.54 (89.8)		
NY□□-PB8-G	1/2 PB	1/2 PB			3.44 (87.4)		
NY□□-FL4	1/4" FITOK	1/4" FITOK			3.50 (88.9)		
NY□□-FL6	3/8" FITOK	3/8" FITOK			3.78 (96.0)		
NY□□-FL8	1/2" FITOK	1/2" FITOK			3.44 (87.4)		
NY□□-ML6	6 mm FITOK	6 mm FITOK			3.78 (96.0)		
NY□□-ML8	8 mm FITOK	8 mm FITOK			3.78 (96.0)		
NY□□-ML12	12 mm FITOK	12 mm FITOK			3.78 (96.0)		

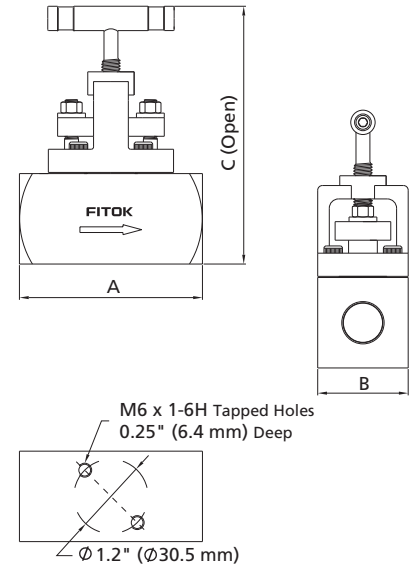

1. Connection type of "FITOK" means FITOK double ferrule tube fittings. When the connection type of valves is FITOK double ferrule tube fitting, the working pressures of the valves are related to the wall thickness of tubing applied. For specific working pressure of the valves, please refer to the allowable working pressures in FITOK Catalog Tubing.
2. Connection type of "PS" means pipe socket weld. "PB" means pipe butt weld.
3. Sizes and types listed are standard. Other sizes and types are available upon request. For details, please contact FITOK Group or our authorized distributors.
4. Dimensions are shown with FITOK tube fitting nuts finger-tight. All dimensions not shown above, please contact FITOK Group or our authorized distributors.

Ordering Number Description

NYSS - FL8 - ML12 - WB - GY - SF2

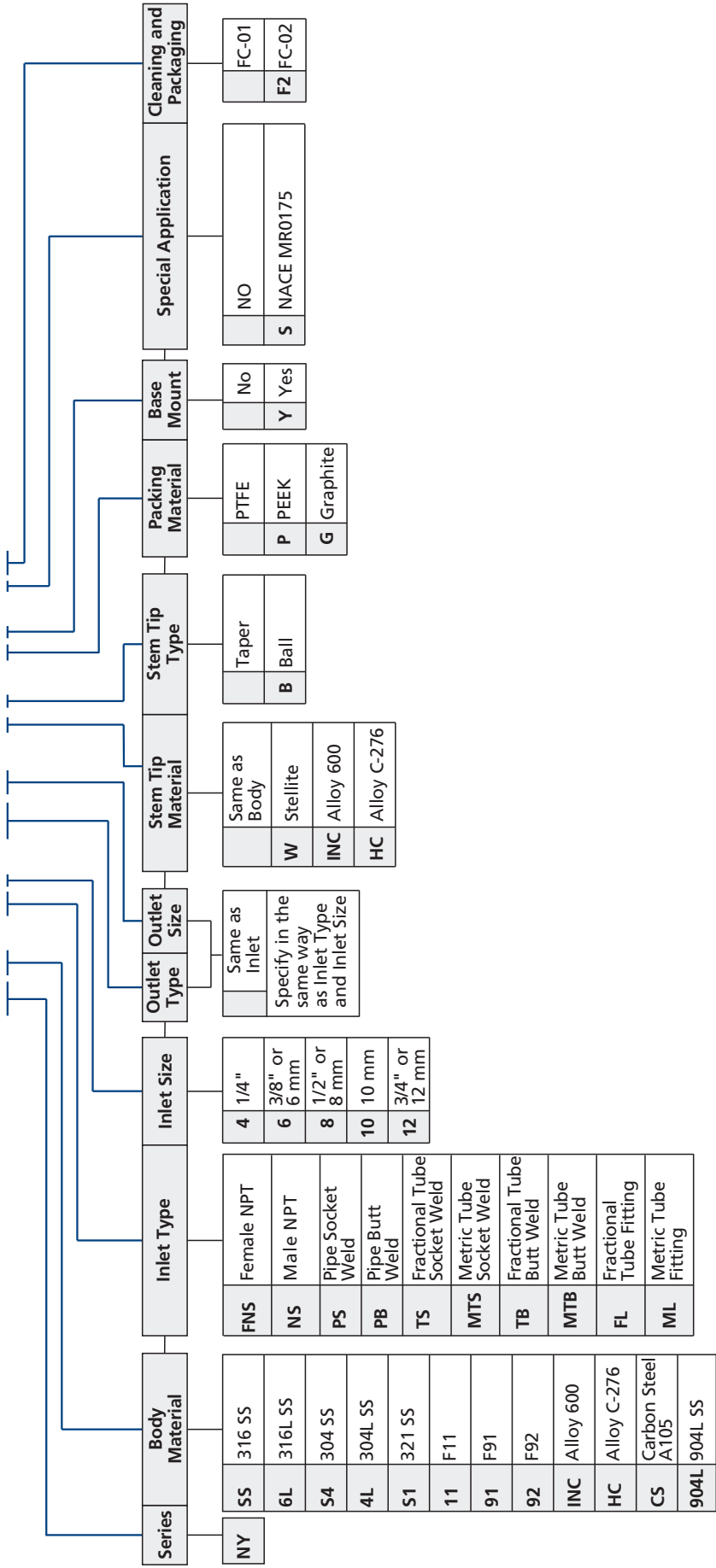

NOTE: "Ordering Number Description" is a reference to understand the combination rules of FITOK product part number. Not all combinations are available.

Cleaning and Packaging:

FC-01: Standard cleaning and packaging for general industrial procedures.

FC-02: Special cleaning and packaging for wetted system components to ensure compliance with product cleanliness requirement of ASTM G93 Level C.

info@fitok.com
www.fitok.com

FK-IC-GV-02-EN-221220